

The Q-Series



The Q-Series

The **Q-Series** continues the established d&b audiotechnik approach to the design and manufacture of loudspeaker systems, adding another dimension to d&b's maxima. It is designed for a wide range of small to medium scale applications and a clear perspective to provide flexible, configurable array solutions to the most arduous sound reinforcement situations. Control of dispersion behaviour is a particular fixation at d&b, while at the same time keeping the size and weight of systems to an absolute minimum. It also embodies the d&b holistic approach to sound reinforcement solutions: integrating loudspeakers, electronics, mechanical deployment assemblies, remote control functions and setup design tools for precise calculation of array performance. The Q-Series maintains the "d&b specific" combination of a neutral, intelligible sound character that is clear and transparent even at high sound pressure levels providing the engineer with an efficient, effortless tool and a neutral platform.

The scope of applications for the Q-Series is intentionally very broad, ranging from single loudspeakers right through to larger multiple cabinet arrays for locations which all share the same fundamental requirements, acoustical and mechanical compatibility to achieve precise control of directivity that is maintained to the lowest possible frequency. The Q-Series uses a variety of technologies to create a group of loudspeakers that perfectly satisfies this demand: conventional rotatable CD horns, dipolar driver arrangements, low compression vented designs with high excursion drivers and toroidal wave shaping devices, all integrated using line array principals.

The Q-Series loudspeakers are the perfect option for speech and music in many theatre and presentation situations, live television and orchestral shows, situations where multiple open microphones are used and considerable gain before feedback is an absolute requirement. The transparency, bandwidth, high power and headroom capabilities also makes the Q-Series ideal for any type of amplified music. The Q-Series has a full range of specially designed rigging to allow quick and simple deployment in all intended applications, whether ground supported or flown. The use of neodymium magnets in the driver assemblies increases the ratio of weight against output power to significantly higher levels. The d&b ArrayCalc calculator predicts the performance of arrays, enabling simple and accurate system planning and removing the usual trial and error in highly pressured onsite situations.

The 2-way passively crossed over **Q1**, **Q7** and **Q10** loudspeaker cabinets are designed to be totally mechanically compatible, sharing the same physical size, shape, rigging and driver compliment. The highest degree of constant directivity is maintained using a large frequency overlap through the crossover range, while the

recessed dipolar positioning of the two 10" low frequency drivers mechanically time aligns these with the 1.3" exit HF driver. The Q1 HF driver is fitted with a toroidal wave shaping device, which has a 75° (h) dispersion pattern, and the resulting curved coherent wave front allows vertical arrays of multiple cabinets to be constructed. The Q7 and Q10 loudspeakers also use a 1.3" HF driver fitted to rotatable 75° x 40° and 110° x 40° (h x v) constant directivity horns allowing them to be configured for use both vertically or horizontally. When deployed upright, the Q7 and Q10 are accurate stand-alone full range loudspeakers with vertical directivity control extending approximately one octave below similarly sized biaxial loudspeakers.

Their horizontal coverage angles can also be used to fulfil near field or infill functions for Q1 arrays, either flown, stacked or ground supported. When deployed horizontally with the horn rotated, the horizontal dispersion control of the Q7 is maintained down to approximately 400 Hz. This performance can be used very effectively in critical positions close to open microphones and also allows the Q7 loudspeaker to be combined as the near field element in Q1 columns.

The **Q-SUB** completes the Series sharing the same width as the other three loudspeakers and has compatible flying fittings enabling its use in columns with other Q-Series loudspeakers. The Q-SUB is a bass-reflex design with an 18" high excursion driver. Multiples of three Q-SUBs can be combined to produce Cardioid Subwoofer Arrays (CSA) when driven by the D6 or D12 amplifier. The D12 amplifier incorporates d&b SenseDrive technology for accurate control of driver membranes.

The d&b **D6** and **D12** dual channel amplifiers realize the complete system. They provide two different power ranges, incorporate d&b loudspeaker specific configuration information, including the Q-Series loudspeakers and have analog and digital signal inputs and links. These devices are specially designed and manufactured by d&b utilizing Digital Signal Processing and include switchable functions for precisely tailoring system response for a wide variety of applications. A user definable 4-band parametric equalizer and a delay capability is provided in every amplifier channel to reduce the need for external processing devices. The D12 amplifier additionally offers a 2-Way Active mode and a mixed TOP/SUB output configuration, output connector options as well as d&b SenseDrive.

Both amplifiers have **d&b Remote network** interfaces enabling control and monitoring of a large number of system functions and extensive system integration capabilities. d&b Load monitoring and System check are also incorporated to remotely monitor loudspeaker driver status.

The Q-Series



Q1 loudspeaker



Q7, Q10 loudspeaker



Q subwoofer



D6 amplifier



D12 amplifier

The D6 and D12 amplifiers

D6 and D12 amplifiers

The D6 and D12 are dual channel amplifiers developed and manufactured by d&b utilizing Digital Signal Processing (DSP) to incorporate loudspeaker specific configuration information and functions. These are designed for use with d&b loudspeakers, have both digital and analog signal inputs as well as link outputs, remote control and monitoring capabilities and switch mode power supplies. The level control incorporates a digital rotary encoder enabling selection of all operating modes in conjunction with a Liquid Crystal Display (LCD).

Loudspeaker specific configurations for current d&b loudspeakers and a linear mode are contained within them, the exception being that the D6 does not include 2-Way Active and B2-SUB configurations.

The digital elements of the D6 and D12 are specified and constructed to achieve the best possible audio performance while maintaining a very low latency of 0.3 msec. The Digital Signal Processing is used to provide the loudspeaker specific configurations, sophisticated protection circuits modelling thermal and mechanical driver behaviour, and switch functions.

User definable equalization and delay functions are incorporated in each channel of the amplifiers and can be used for applications such as front fills or under balcony delays without the need for external processors. The signal delay capability allows delay settings of up to 340 msec. (= 100 m/328 ft) to be applied independently to each channel as can the 4-band parametric equalizer, providing optional Boost/Cut or Notch filtering. A signal generator offering pink noise or sine wave program is also incorporated for test and alignment purposes. Every unit can be given a unique Device Name to simplify identification and a password protected LOCK function is also incorporated to prevent unauthorized changes.

The D6 and D12 amplifiers also detect incoming Pilot signals at its input (Input monitoring) and can use Load monitoring and System check functions to determine the status of the loudspeaker impedance. d&b System check is designed to verify that the system performs within a predefined condition and can be used to report the system condition after a show.

d&b Load monitoring, on the other hand, enables automatic and continuous impedance monitoring and along with Input monitoring is designed for incorporation within applications specified to the requirements stated in the International Standard IEC 60849 'Sound Systems for Emergency Purposes'. Both can determine the status of an LF or HF driver in systems with multiple elements, even if these are crossed over passively.

The D6 utilizes a switch mode power supply with PFC suitable for mains supply voltages 100 V/115 V/200 V/230 V, 50 - 60 Hz whilst the D12 utilizes an autosensing switch mode power supply for mains voltages 115/230 V, 50 - 60 Hz (optional 100/200 V). Both power supplies have over voltage protection and each amplifier has a temperature and signal controlled fan to cool the internal assemblies.

The 2 RU lightweight D6 is specifically designed to deliver medium power into low impedance loads between 4 and 16 ohms. The 3 RU D12 is specifically designed to produce high power into low impedance loads, typically those between 4 and 16 ohms. Due to differences in impedance response against frequency, the maximum number of cabinets driven by each D12 channel varies depending on the loudspeaker type.

Apart from selectable output configurations for dual channel, Mix TOP/SUB and 2-Way Active mode, the D12 also provides d&b SenseDrive for use with the LF drivers in d&b active loudspeakers and subwoofers.

Both amplifiers house an I/O panel containing: analog signal inputs with link outputs for each channel, an AES/EBU digital input with a link output and NL4 loudspeaker outputs. The D12 I/O panel additionally offers the options of EP5 or NL8 loudspeaker outputs. The two RJ 45 REMOTE sockets at the rear of the D6 and the D12 amplifiers integrate them into the d&b Remote network via CAN-Bus, enabling remote control and/or monitoring.

A USB-B (D6) or a SUB-D9 (D12) SERVICE interface is provided to enable future firmware updates containing new loudspeaker configurations or additional functions to be loaded to the units.

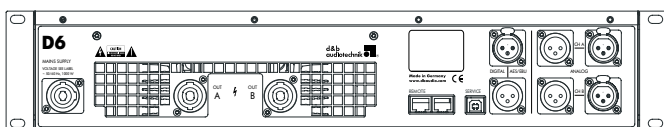

D6 rear view

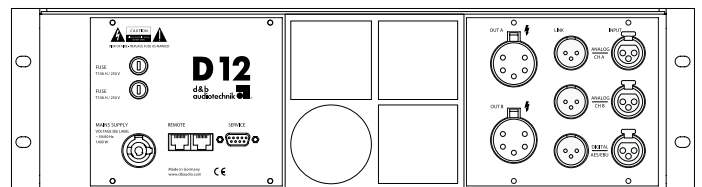

D12 rear view

The D6 and D12 amplifier data

D6 Display

ISP, GR, OVL A/B.....LED indicators
Liquid Crystal Display (LCD).....Graphic display/120 x 32 Pixel

D6 Controls

POWER, MUTE/LEVEL.....Switch, rotary encoder
Function switches.....Loudspeaker specific circuits
4-band equalizer.....Optional PEQ/Notch
Delay setting.....0.3 - 340 msec. with 0.1 msec. detents
Configurations.....Current d&b loudspeakers and linear mode
.....except 2-Way Active and B2-SUB
Frequency generator.....Pink noise or Sine wave

D6 Connectors

INPUT/LINK ANALOG A/B.....3 pin XLR female/male¹
INPUT/LINK DIGITAL AES/EBU.....3 pin XLR female/male¹
Sampling rate.....48 kHz/96 kHz
OUT CHANNEL A/B.....NL4
REMOTE.....2 x RJ 45 parallel
SERVICE.....USB Type B

D6 Protection circuits

Mains inrush current limiter.....1.5 A RMS at 230 V
Loudspeaker switch on delay.....Approx. 2 sec.
Overvoltage protection.....Up to 400 VAC

D6 Data (linear setting with subsonic filter)

Rated output power (THD+N < 0.1%).....
.....2 x 350 W into 8 ohms, both channels are driven
.....2 x 600 W into 4 ohms, both channels are driven
S/N ratio (unweighted, RMS).....>110 dBr

D6 Digital Signal Processing

Sampling rate.....96 kHz/27 Bit ADC/24 Bit DAC
Basic delay/latency analog input.....0.3 msec.

D6 Power supply

Switch mode power supply for.....
.....100/115/200/230V, 50 - 60 Hz
Mains connector.....PowerCon®²

D6 Remote network

Remote network.....CAN-Bus

D6 Dimensions, weight

Height x width x depth.....2 RU x 19" x 353 mm/13.9"
Weight.....8 kg/17.6 lb

D12 Display

ISP, GR, OVL A/B.....LED indicators
Liquid Crystal Display (LCD).....Graphic display/120 x 32 Pixel

D12 Controls

POWER, MUTE/LEVEL.....Switch, rotary encoder
Function switches.....Loudspeaker specific circuits
4-band equalizer.....Optional PEQ/Notch
Delay setting.....0.3 - 340 msec. with 0.1 msec. detents
Configurations.....Current d&b loudspeakers and linear mode
Frequency generator.....Pink noise or Sine wave

D12 Connectors

INPUT/LINK ANALOG A/B.....3 pin XLR female/male¹
INPUT/LINK DIGITAL AES/EBU.....3 pin XLR female/male¹
Sampling rate.....48 kHz/96 kHz
OUT CHANNEL A/B.....Optional EP5/NL4/NL8
REMOTE.....2 x RJ 45 parallel
SERVICE.....SUB-D9 female

D12 Protection circuits

Mains inrush current limiter.....5 A RMS at 230 V
Loudspeaker switch on delay.....Approx. 2 sec.
Overvoltage protection.....Up to 400 VAC

D12 Data (linear setting with subsonic filter)

Rated output power (THD+N < 0.1%).....
.....2 x 750 W into 8 ohms, both channels are driven
.....2 x 1200 W into 4 ohms, both channels are driven
S/N ratio (unweighted, RMS).....>110 dBr

D12 Digital Signal Processing

Sampling rate.....96 kHz/27 Bit ADC/24 Bit DAC
Basic delay/latency analog input.....0.3 msec.

D12 Power supply

Autosensing switch mode power supply for.....
.....115/230 V, 50 - 60 Hz
.....optional 100/200 V, 50 - 60 Hz
Mains connector.....PowerCon®²

D12 Remote network

Remote network.....CAN-Bus

D12 Dimensions, weight

Height x width x depth.....3 RU x 19" x 353 mm/13.9"
Weight.....13 kg/29 lb

¹ XLR pin assignment analog, inputs and links: 1 = GND, 2 = pos. signal, 3 = neg. signal
XLR pin assignment digital, input and link: 1 = GND, 2 = signal, 3 = signal

² PowerCon® is a registered trademark of the Neutrik AG, Liechtenstein

The d&b Remote network

d&b Remote network

The d&b Remote network enables central control and monitoring of a complete d&b loudspeaker system from anywhere in the network, be it from a PC in the control room, at the mix position, or on a wireless tablet PC in the auditorium.

This central access to all functions, controls and detailed system information unlocks the full potential of the d&b system approach. Extensive monitoring and diagnostics enables detailed examination of the system performance. Control can be undertaken on individual loudspeakers, on multiple groups of loudspeakers or formed into groups that address the complete system.

The flexibility and scalability of this approach, coupled with the inclusion of several types of interfaces, allow the d&b Remote network to be deployed to address the differing control and monitoring requirements in a broad variety of mobile and installed applications, regardless of their size.

In mobile applications, system engineers may use the remote network to verify and tune the system. System check and device diagnostics enable detailed monitoring as and when required, before, during, or after a show.

In installation projects system integrators can configure the remote network to offer access to different levels of control tailored to the operational demands. For example, simplified functionality for daily use and more complex functionality when multiple applications are required within one installation. Input and Load monitoring coupled with automatic error messages allow installation operators to ensure the optimum performance at all times.

d&b Remote interfaces

Every d&b amplifier is fitted with a Remote interface for the Controller Area Network (CAN) Bus. Each D6 and D12 has two REMOTE connectors (RJ 45) to enable the CAN-Bus signal to be daisy chained through them. A simple d&b Remote network application consists of a computer running R1 Remote control software, an R60 USB to CAN interface, CAT 5 shielded twisted pair cable with shielded RJ 45 connectors and d&b D6 or D12 amplifiers.

Up to five R60 USB to CAN interfaces can be operated with one computer running R1, while a maximum of 504 amplifiers can be incorporated into one application. The maximum bus cable length of a d&b Remote network is 600 metres, see the adjoining table for cable length examples. The R70 Ethernet to CAN interface can be used for applications over longer distances, in conjunction with a fibre optic network for example.

For further information about CAN-Bus cabling requirements and interfaces please refer to the d&b TI 312 d&b Remote network, which is available for download at www.dbaudio.com.

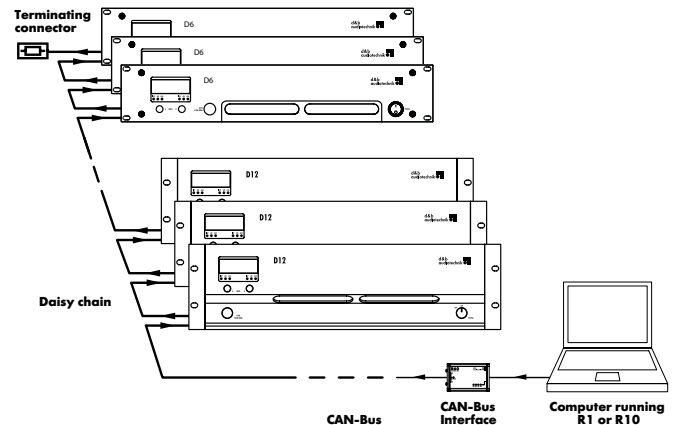

d&b Remote network

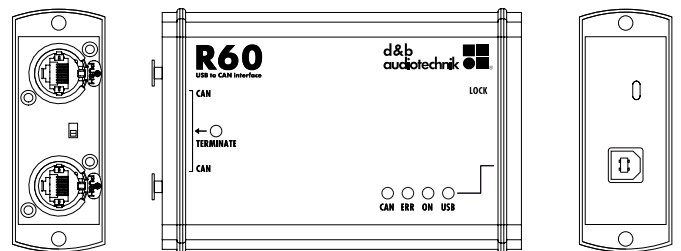

Z6118 R60 USB to CAN interface

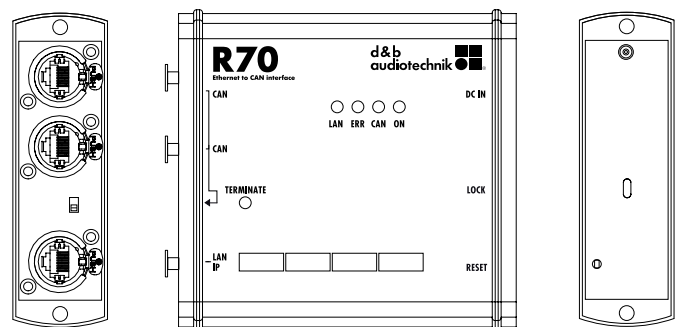

Z6124 R70 Ethernet to CAN interface

Cable cross section	Maximum bus cable length with numbers of amplifiers	
	32	100
0,25 mm ² (24 AWG)	180 m (600 ft)	140 m (460 ft)
0,75 mm ² (18 AWG)	500 m (1650 ft)	330 m (1100 ft)

Examples of bus cable length

The d&b Remote software



R1 main page, groups and master controls

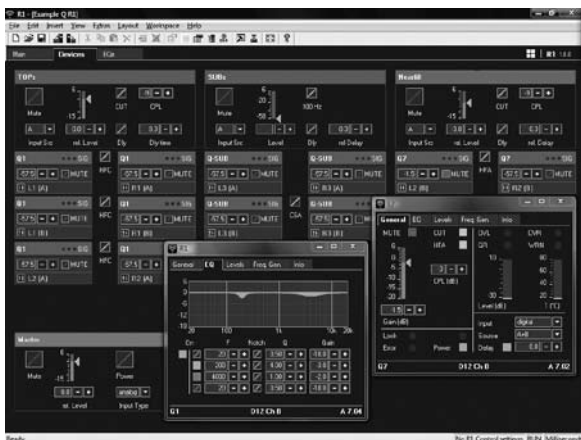

R1 device page, individual devices, details view and group controls

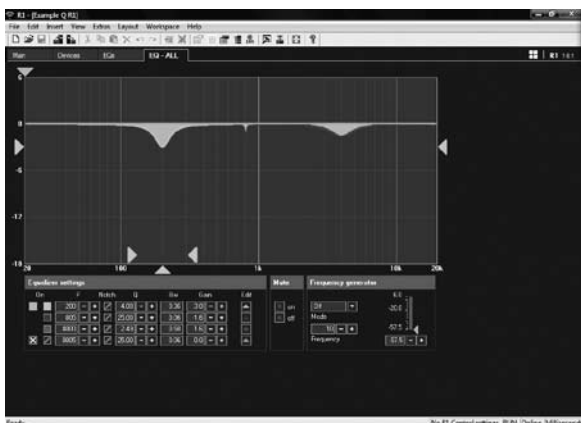

R1 equalizer page

R1 Remote control software

R1 Remote control software is a graphical drag and drop user interface enabling the construction of a screen based virtual control surface for d&b systems, using the d&b Remote network.

All major features, functions and controls available on the front panel of the D6 and D12 amplifiers may be remotely controlled and/or monitored using R1. The architecture of R1 allows control of each channel of the amplifier as a single entity and enables the creation of groups of loudspeakers in as little, or as much detail as required by the user. When grouped together, a button or fader can control the overall system level, zone level, equalization and delay, power ON/OFF, MUTE and loudspeaker function switches such as CUT/HFA/HFC or CPL.

R1 has extensive facilities for storing and recalling system settings allowing these to be repeated, as and when required. It is easy to adjust R1 project files for use with a different set of equipment at another location. Password protection is available to restrict access. R1 runs on PCs operating Microsoft Windows XP SP3/Vista SP1/7. A virtual machine enables R1 to run on the newer Intel² Mac³ in parallel to the Mac OS³ X, using the Windows driver for R60 USB to CAN interface.

For older, Power PC based Mac computers, Windows emulation needs to be used, together with the R60 driver for Mac/PPC. For R70 Ethernet to CAN, no driver is needed.

All the latest available drivers, R1 example files that can be used as templates and the TI 391 describing the effective use of R1 are available for download at www.dbaudio.com.

R10 Service software

R10 Service software enables the simultaneous amplifier firmware update of up to 63 amplifiers from a central location. Using R10, AmpPresets can be adjusted to the application requirements.

Integration with media control

For integration of d&b audiotechnik loudspeaker systems into media control applications, the R70 Ethernet to CAN interface is used. Media control modules (drivers) are available at www.dbaudio.com.

EN 60849 voice alarm applications

For remote control of voice alarm applications Programmable Logic Controllers (PLCs) can be integrated into the d&b Remote network.

¹ Microsoft and Windows XP/Vista/7 are either registered trademarks or trademarks of Microsoft Corporation in the United States and/or other countries

² Intel is a trademark of the Intel Corporation in the United States and other countries

³ Mac and Mac OS are trademarks of Apple Inc., registered in the United States and other countries

The Q1 loudspeaker

Q1 loudspeaker

The Q1 is a line array loudspeaker for use in vertical columns giving a 75° constant directivity dispersion pattern in the horizontal plane. The Q1 cabinet is a passive 2-way design that houses 2 x 10" LF drivers and a 1.3" HF compression driver with a toroidal waveshaping device to achieve a 75° horizontal dispersion characteristic. The two 10" neodymium LF drivers are positioned in a dipolar arrangement providing an exceptional dispersion control even at lower frequencies, with the 75° nominal dispersion angle being maintained down to 400 Hz.

Q1 cabinets can be combined with the Q subwoofer system; in line array setups with the Q-SUB flown on top of the array or as a separate column, or in ground stacked applications where the Q-SUB also mechanically supports the Q1s. The Q-SUB extends the system frequency response to below 40 Hz, for further extension of bandwidth and headroom ground stacked B2 subwoofers can be used (driven in INFRA mode).

The Q1 cabinet is constructed from marine plywood and has an impact resistant paint finish. The front of the loudspeaker cabinet is protected by a rigid metal grill covered with a replaceable acoustically transparent foam. The cabinet incorporates a pair of handles and mounted on the rear panel are two EP5 or NL4 connectors wired in parallel.

System data

Frequency response (-5 dB standard).....	60 Hz - 17 kHz
Frequency response (-5 dB CUT mode).....	100 Hz - 17 kHz
Max. sound pressure (1 m, free field) ¹	
with D6.....	135 dB
with D12.....	139 dB
Input level (100 dB SPL/1 m).....	- 18 dBu

Loudspeaker data

Nominal impedance.....	8 ohms
Power handling capacity (RMS/peak 10 ms).....	400/1600 W
Nominal dispersion angle (h).....	75°
Components.....	2 x 10" driver/1.3" compression driver
.....	passive crossover network
Connections.....	2 x EP5, optional 2 x NL4
Pin assignments.....	EP5: 1/2 (NL4: 1+/1-)
Weight.....	22 kg (49 lb)

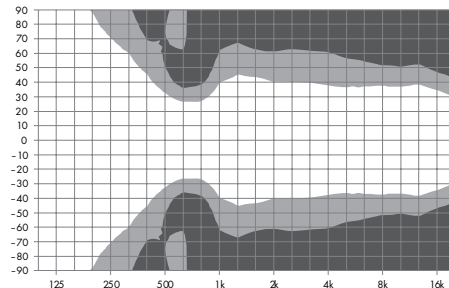

Q1 horizontal dispersion characteristics²

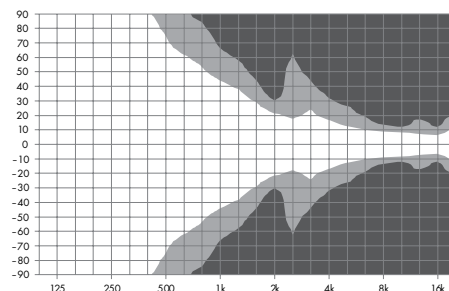

Q1 vertical dispersion characteristics²

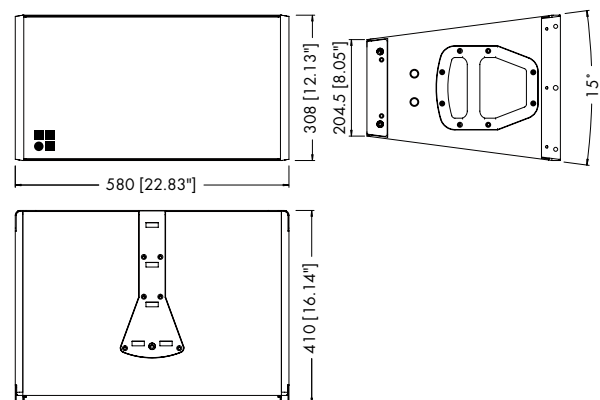

Q1 cabinet dimensions in mm [inch]

¹ Broadband measurement, pink noise, crest factor 4, peak measurement, linear weighting

² Dispersion angle vs frequency plotted using lines of equal sound pressure (isobars) at -6 dB and -12 dB

The D6 and D12 configurations

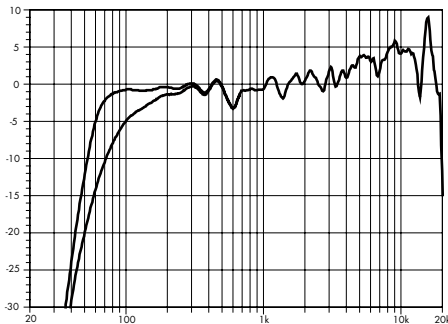

Q1 frequency response, standard and CUT modes (single cabinet)

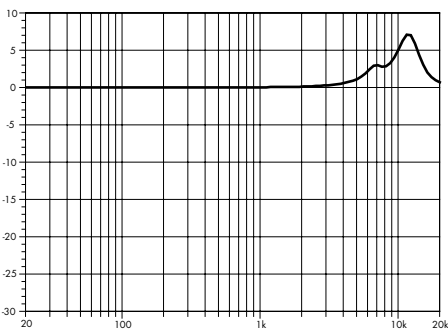

Frequency response correction of HFC circuit

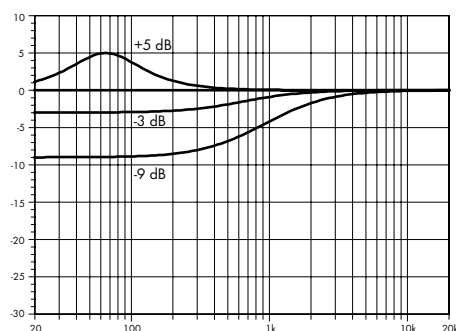

Frequency response correction of CPL circuit

Q1 with D6 and D12

Selecting Q1 mode in the D6 and D12 dual channel amplifiers enables up to two Q1 loudspeakers to be driven by the respective channel. In applications with low continuous levels and low ambient temperatures up to three loudspeakers per D12 channel may be connected.

A Q1 line configuration is available in D6 and D12 for groups of four or more Q1 loudspeakers, which are coupled to a straight long throw array section. Compared to the standard configuration, the mid/high range is reduced to compensate for the extended near field.

For acoustic adjustment the functions CUT, HFC and CPL can be selected.

Set to CUT, the Q1 low frequency level is reduced. The Q1 is now configured for use with the Q-SUB or B2-SUB.

Selecting the HFC (High Frequency Compensation) circuit compensates for loss of high frequency energy due to absorption in air when loudspeakers are used to cover far field listening positions. The HFC circuit should be used selectively, only for those cabinets covering distances larger than 50 m (160 ft). This enables the correct sound balance between close and remote audience areas, whilst all amplifiers driving the array can be fed with the same signal.

The CPL (Coupling) circuit compensates for coupling effects between the cabinets; these effects increase as the length of the line array is extended. CPL begins gradually at 1 kHz, with the maximum attenuation below 400 Hz, providing a balanced frequency response when Q1 cabinets are used in arrays of four or more. The function of the CPL circuit in these amplifiers is shown in the diagram opposite and can be set in dB attenuation values between -9 and 0, or a positive CPL value which creates an adjustable low frequency boost around 65 Hz (0 to +5 dB).

The Q1 rigging system

Q1 rigging system

The Q1 cabinet is fitted with rigging attachments. Sockets in the front grill and rear edge bar accept Locking pins 8 mm, a quick lock adapter plate and sockets that accept the Flying pin 10 mm. Flown and ground stacked Q1 arrays are assembled using the Q Rigging set, containing two Q Splay and two Q Front links as well as four Locking pins 8 mm, which is supplied with each Q1 loudspeaker.

The Q Flying adapter attaches to the quick lock adapter plate located on one side of the cabinet. It is designed to support a maximum of three Q-Series loudspeakers. Five sockets that accept the Flying pin 10 mm may be used to suspend single cabinets or to secure the aiming of an array.

The Q Flying frame is designed to support a maximum of twenty Q1 loudspeakers. The hole on the top of the Flying frame that is selected as the suspension point defines the total vertical array angle of the column.

The Q Load adapter is attached to the top of the Q Flying frame and increases the vertical aiming of a column of Q-Series loudspeakers by 1/2 or 1/4 detents. The Q Load adapter comes with a 2 t Shackle to accept the Q Hoist connector chain or can be directly combined with the Rota clamp.

The Q Hoist connector chain can be attached directly to the Q Flying frame for flown arrays of up to twenty cabinets. It also prevents the chain bag interfering with the exact aiming of an array by inserting a space between the suspension point and the lifting motor.

The Rota clamp is used to suspend an array from a single overhead bar or truss and allows rotation to aim it correctly and then be locked off. It can be used with either the Q Flying adapter or the Q Flying frame. The Rota clamp allows to be suspended from overhead bars or truss with a tube diameter up to 51 mm (2").

Safety approval

d&b loudspeakers and accessories are designed for set up and use within situations requiring compliance with the provisions and directives of BGV C1 Rule for the Prevention of Accidents.



Z5151
Q Splay link



Z5152
Q Front link



Z5153
Locking pins 8 mm

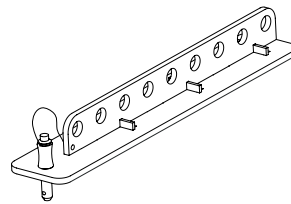

Z5156
Q Flying adapter

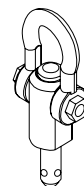

Z5048
Flying pin 10 mm

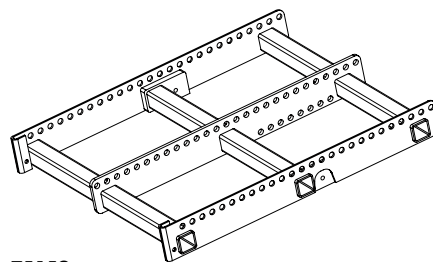

Z5159
Q Flying frame

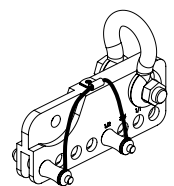

Z5160
Q Load adapter



Z5155
Q Hoist connector chain

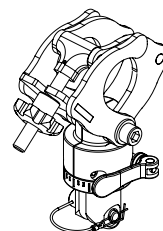

Z5147
Rota clamp

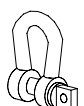

E6507
1t Shackle

The Q1 rigging examples

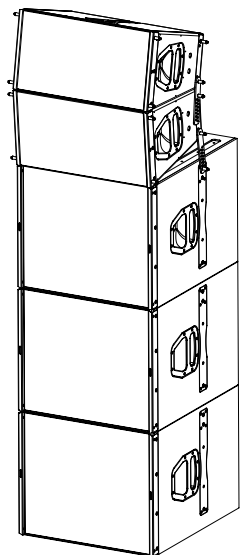

Q1 ground stack with Q-SUB

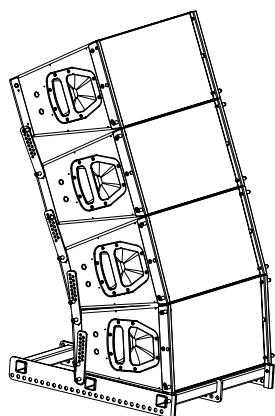

Q1 ground stack with Z5159 Q Flying frame

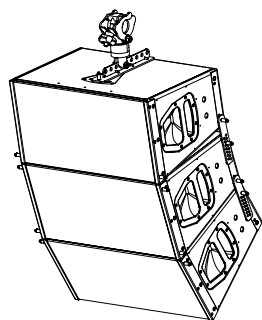

Q1 array with Z5156 Q Flying adapter Z5147 Rota clamp

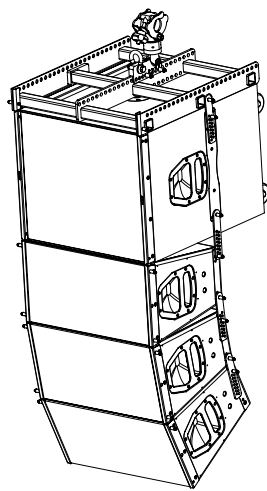

Q1/Q-SUB array with Z5159 Q Flying frame Z5147 Rota clamp Z5160 Q Load adapter

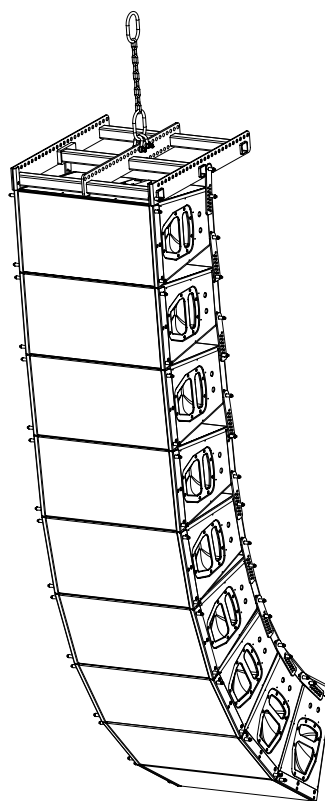

Q1 line array with Z5159 Q Flying frame Z5155 Q Hoist connector chain E6507 1t Shackles

Q1 rigging examples

With a 15° vertical HF dispersion per cabinet, the Q1 can be used to construct vertical columns that produce a curved coherent wave front. The mechanical and acoustical design of the cabinet enables vertical splay angles to be set between 0° and 14° . Q1 cabinets can therefore be used in vertical configurations starting from two cabinets with a 15° to 30° dispersion, up to twenty cabinets with a fully user and venue defined vertical profile. For further information please refer to the d&b T1 385 J, Q and T-Series system design, d&b ArrayCalc, which is available for download at www.dbaudio.com.

The Q7 loudspeaker

Q7 loudspeaker

The Q7 is a 75° x 40° passive 2-way loudspeaker housing 2 x 10" LF drivers and a 1.3" HF compression driver with a rotatable constant directivity horn and a passive crossover network. The two 10" neodymium LF drivers are positioned in a dipolar arrangement providing exceptional vertical dispersion control with the 40° nominal angle being maintained down to 400 Hz. The precisely controlled 75° horizontal dispersion performance provides the ideal pattern for many medium throw requirements. The Q7 horn can be rotated by 90° without removing the metal grill. The Q7 rotated setup is used to mount the loudspeaker horizontally where space is limited, or the maximum horizontal pattern control is needed. This rotated setup is also used when Q7s are added to the bottom of Q1 arrays.

The Q7 can be used as a stand-alone full range system in combinations with other Q-Series cabinets, ground stacked or mounted on a high stand with a swivel bracket. Q7 cabinets can also be combined in flown array systems using the Q-Series rigging accessories.

The Q7 cabinet is constructed from marine plywood and has an impact resistant paint finish. The front of the loudspeaker cabinet is protected by a rigid metal grill, covered with a replaceable acoustically transparent foam. The cabinet incorporates a pair of handles and mounted on the rear panel are two EP5 or NL4 connectors wired in parallel.

System data

Frequency response (-5 dB standard).....	60 Hz - 17 kHz
Frequency response (-5 dB CUT mode).....	100 Hz - 17 kHz
Max. sound pressure (1 m, free field) ¹	
with D6.....	134 dB
with D12.....	138 dB
Input level (100 dB SPL/1 m).....	- 17 dBu

Loudspeaker data

Nominal impedance.....	8 ohms
Power handling capacity (RMS/peak 10 ms).....	400/1600 W
Nominal dispersion angle (h x v).....	75° x 40°
Components.....	2 x 10" driver/1.3" compression driver
.....	passive crossover network
Connections.....	2 x EP5, optional 2 x NL4
Pin assignments.....	EP5: 1+/1-)
Weight.....	22 kg (49 lb)

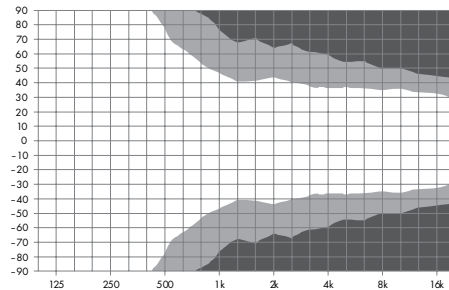

Q7 horizontal dispersion characteristics¹

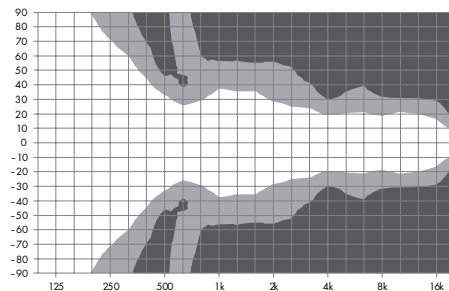

Q7 vertical dispersion characteristics²

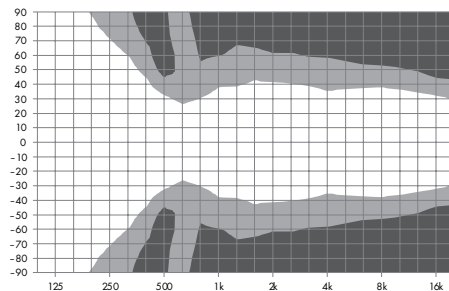

Q7 horizontal dispersion characteristics/rotated horn²

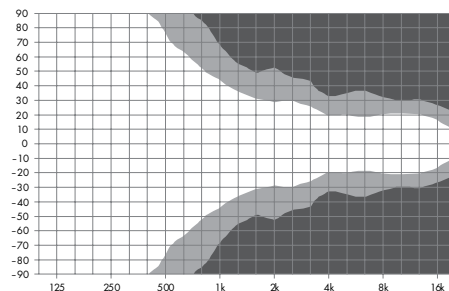

Q7 vertical dispersion characteristics/rotated horn²

¹ Broadband measurement, pink noise, crest factor 4, peak measurement, linear weighting
² Dispersion angle vs frequency plotted using lines of equal sound pressure (isobars) at -6 dB and -12 dB

The D6 and D12 configurations

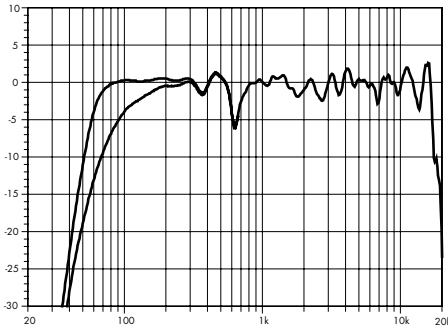

Q7 frequency response, standard and CUT modes

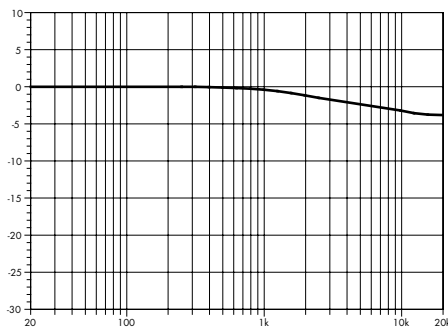

Frequency response correction of HFA circuit

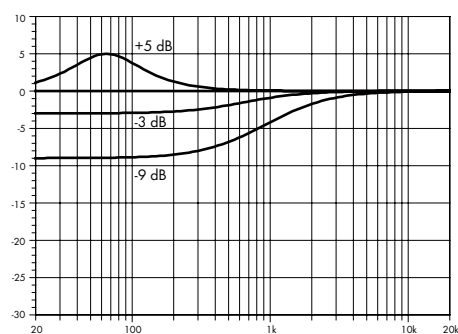

Frequency response correction of CPL circuit

Q7 with D6 and D12

Selecting Q7 mode in the D6 and D12 dual channel amplifiers enables up to two Q7 loudspeakers to be driven by the respective channel. In applications with low continuous levels and low ambient temperatures up to three loudspeakers per D12 channel may be connected.

For acoustic adjustment the functions CUT, HFA and CPL can be selected.

Set to CUT, the Q7 low frequency level is reduced. The Q7 is now configured for use with the Q-SUB or B2-SUB.

In HFA mode (High Frequency Attenuation), the HF response of the Q7 system is rolled off. The HFA provides a natural, balanced frequency response when a unit is placed close to listeners in near field or delay use. High Frequency Attenuation begins gradually at 1 kHz, dropping by approximately 3 dB at 10 kHz. This roll off mimics the decline in frequency response experienced when listening to a system from a distance in a typically reverberant room or auditorium.

The CPL (Coupling) circuit compensates for coupling effects between the cabinets when building closely coupled arrays. CPL begins gradually at 1 kHz, with maximum attenuation below 400 Hz, providing a balanced frequency response when Q7 cabinets are used in arrays of two or more. The function of the CPL circuit in these amplifiers is shown in the diagram opposite and can be set in dB attenuation values between -9 and 0, or a positive CPL value which creates an adjustable low frequency boost around 65 Hz (0 to +5 dB).

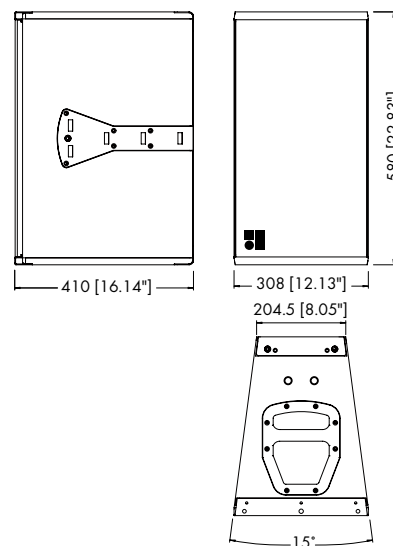

Q7 cabinet dimensions in mm [inch]

The Q10 loudspeaker

Q10 loudspeaker

The Q10 is a 110° x 40° passive 2-way loudspeaker housing 2 x 10" LF drivers and a 1.3" HF compression driver with a rotatable constant directivity horn and a passive crossover network.

The two 10" neodymium LF drivers are positioned in a dipolar arrangement providing exceptional vertical dispersion control with the 40° nominal angle being maintained down to 400 Hz. The Q10 can be used as a stand-alone full range system or in combinations with other Q-Series cabinets ground stacked, or mounted on a high stand with the Q Flying bracket. The Q10's wide constant directivity performance provides remarkable transparency when used in close proximity to listeners. It is also ideally suited to ambient and/or distributed sound reinforcement tasks where orientation within the sound field is critical. When used in the upright configuration the Q10 has a very accurate 110° horizontal constant directivity behaviour that is maintained down to approximately 800 Hz. This performance differs considerably when the cabinet is deployed horizontally with the horn rotated by 90°. In this configuration the horizontal dispersion pattern is much narrower in the 500 Hz - 1 kHz region, hence their use as a downfill in Q1 arrays for example has limitations.

The Q10 cabinet is constructed from marine plywood and has an impact resistant paint finish. The front of the loudspeaker cabinet is protected by a rigid metal grill, covered with a replaceable acoustically transparent foam. The cabinet incorporates a pair of handles and mounted on the rear panel are two EP5 or NL4 connectors wired in parallel.

System data

Frequency response (-5 dB standard)	60 Hz - 17 kHz
Frequency response (-5 dB CUT mode).....	100 Hz - 17 kHz
Max. sound pressure (1 m, free field) ¹	133 dB
with D6.....	137 dB
with D12.....	137 dB
Input level (100 dB SPL/1 m).....	-17 dBu

Loudspeaker data

Nominal impedance.....	8 ohms
Power handling capacity (RMS/peak 10 ms).....	400/1600 W
Nominal dispersion angle (h x v).....	110° x 40°
Components.....	2 x 10" driver/1.3" compression driver
.....	passive crossover network
Connections.....	2 x EP5, optional 2 x NL4
Pin assignments.....	EP5: 1+/2 (NL4: 1+/-)
Weight.....	22 kg (49 lb)

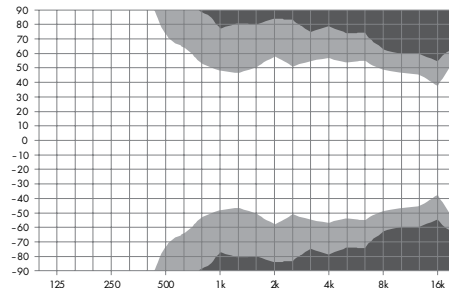

Q10 horizontal dispersion characteristics²

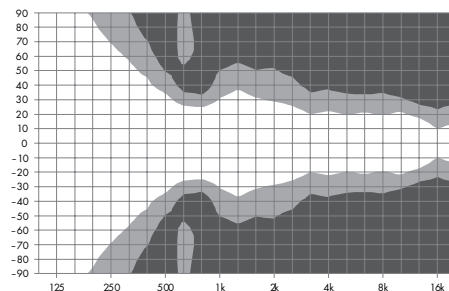

Q10 vertical dispersion characteristics²

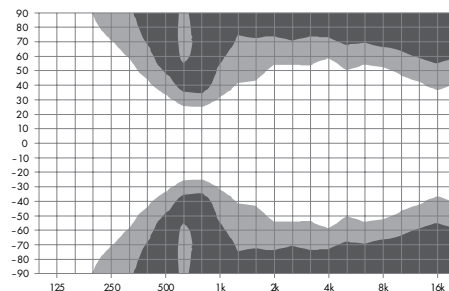

Q10 horizontal dispersion characteristics / rotated horn²

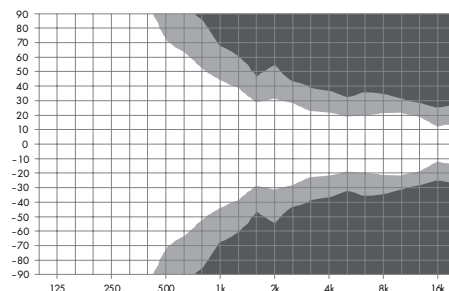

Q10 vertical dispersion characteristics / rotated horn²

¹ Broadband measurement, pink noise, crest factor 4, peak measurement, linear weighting

² Dispersion angle vs frequency plotted using lines of equal sound pressure (isobars) at -6 dB and -12 dB

The D6 and D12 configurations

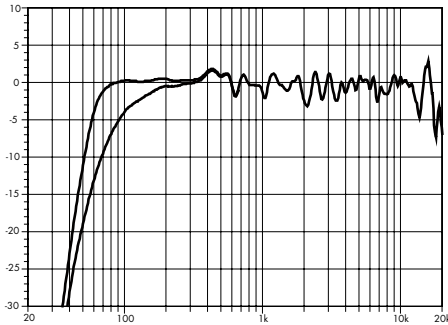

Q10 frequency response, standard and CUT modes

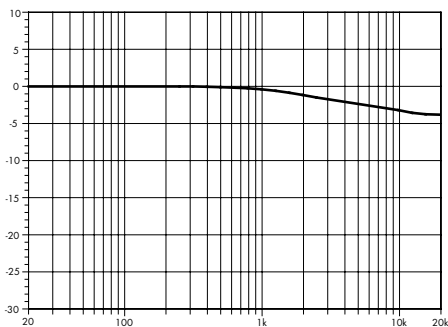

Frequency response correction of HFA circuit

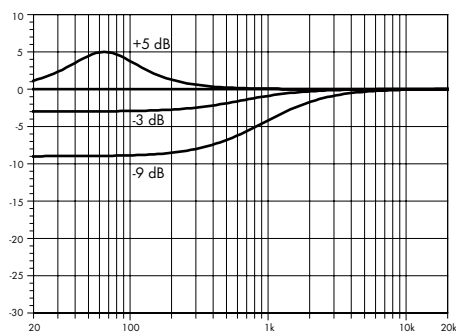

Frequency response correction of CPL circuit

Q10 with D6 and D12

Selecting Q10 mode in the D6 and D12 dual channel amplifiers enables up to two Q10 loudspeakers to be driven by the respective channel. In applications with low continuous levels and low ambient temperatures up to three loudspeakers per D12 channel may be connected.

For acoustic adjustment the functions CUT, HFA and CPL can be selected.

Set to CUT, the Q10 low frequency level is reduced. The Q10 is now configured for use with the Q-SUB or B2-SUB.

In HFA mode (High Frequency Attenuation), the HF response of the Q10 system is rolled off. The HFA provides a natural, balanced frequency response when a unit is placed close to listeners in near field or delay use. High Frequency Attenuation begins gradually at 1 kHz, dropping by approximately 3 dB at 10 kHz. This roll off mimics the decline in frequency response experienced when listening to a system from a distance in a typically reverberant room or auditorium.

The CPL (Coupling) circuit compensates for coupling effects between the cabinets when building closely coupled arrays. CPL begins gradually at 1 kHz, with maximum attenuation below 400 Hz, providing a balanced frequency response when Q10 cabinets are used in arrays of two or more. The function of the CPL circuit in these amplifiers is shown in the diagram opposite and can be set in dB attenuation values between -9 and 0, or a positive CPL value which creates an adjustable low frequency boost around 65 Hz (0 to +5 dB).

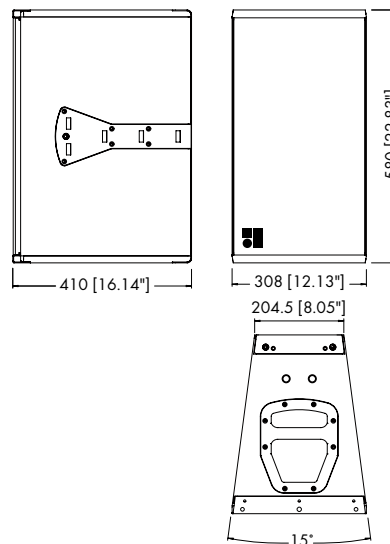

Q10 cabinet dimensions in mm [inch]

The Q7/Q10 rigging accessories

Q7/Q10 rigging accessories

Both the Q7 and Q10 cabinets are fitted with rigging attachments. Threaded inserts at the top and at the bottom of the cabinets accept the Q Flying bracket. It is designed to fit tightly round the loudspeaker to produce the minimum visual impact.

The Q Flying bracket can be fitted to a loudspeaker stand using the Loudspeaker stand adapter or flown using the TV spigot with fixing plate.

The threaded inserts also accept the Flying adapter 02, Flying adapter 03 or Qi Horizontal bracket. Two Qi Horizontal brackets can be connected together using the MAX Bracket connector enabling the construction of horizontal clusters of two Q7/Q10 cabinets.

Sockets in the front grill and rear edge bar accept the Locking pins 8 mm to connect to the Q Splay and Q Front links. The quick lock adapter plate fitted to one side of the cabinet accepts either the Q Swivel bracket or the Q Flying adapter.

Sockets accept the Flying pin 10 mm for supporting single cabinets and for the aiming of arrays.

The Rota clamp is used to suspend an array from single overhead bars or truss with a tube diameter up to 51 mm (2"). It allows rotation to aim it correctly and then locked off.

Safety approval

d&b loudspeakers and accessories are designed for set up and use within situations requiring compliance with the provisions and directives of BGV C1 Rule for the Prevention of Accidents.

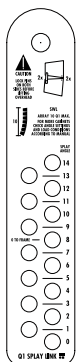

Z5151
Q Splay link



Z5152
Q Front link



Z5153
Locking pins 8 mm

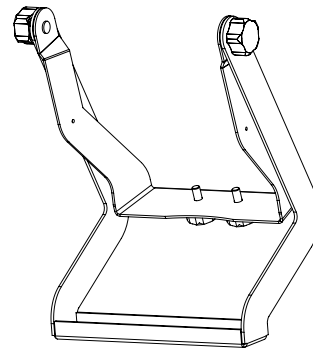

Z5161
Q Flying bracket

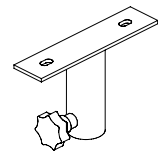

Z5024
Loudspeaker stand adapter

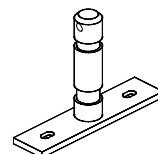

Z5010
TV spigot with fixing plate

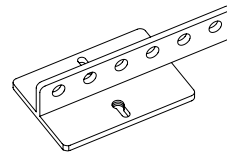

Z5020
Flying adapter 02

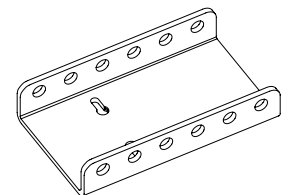

Z5025
Flying adapter 03

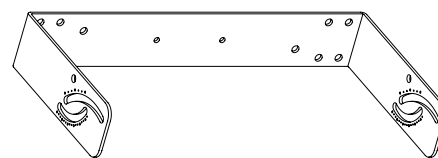

Z5175
Qi Horizontal bracket

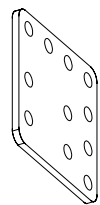

Z5044
MAX Bracket connector

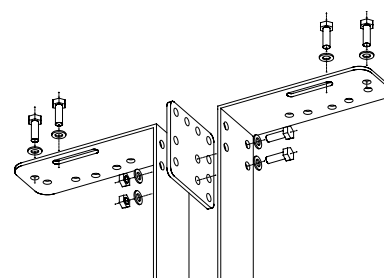

The Q7/Q10 rigging accessories

The Q7/Q10 rigging examples

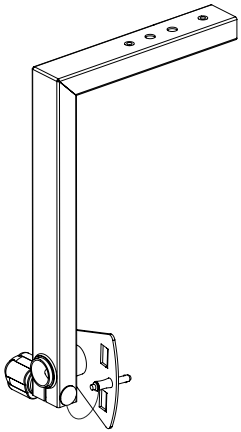

Z5150
Q Swivel bracket

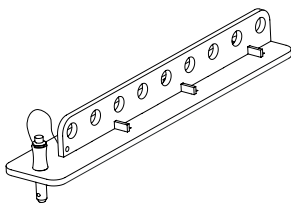

Z5156
Q Flying adapter

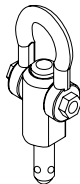

Z5048
Flying pin 10 mm

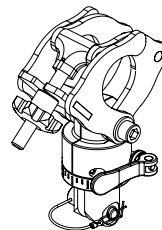

Z5147
Rota clamp

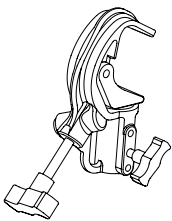

Z5012
Pipe clamp for TV spigot

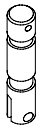

Z5015
TV spigot 02



Q9032
M10 Safety eyebolt

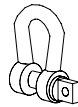

E6507
1t Shackle

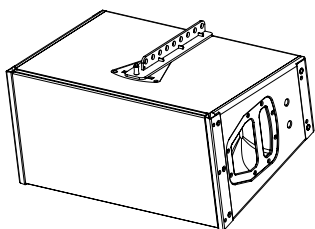

Q7/Q10 with
Z5156 Q Flying adapter

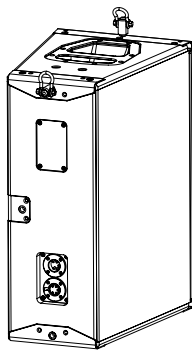

Q7/Q10 with
Z5048 Flying pins 10 mm

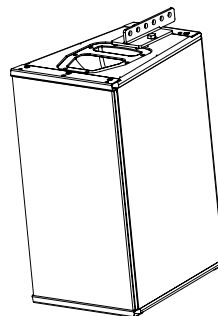

Q7/Q10 with
Z5020 Flying adapter 02

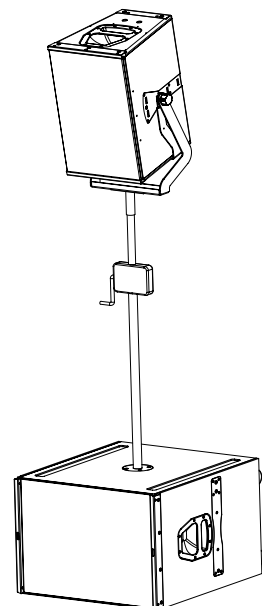

Q7/Q10 and Q-SUB with
Z5161 Q Flying bracket
Z5013 Loudspeaker stand winder M20

The Q subwoofer

Q subwoofer

The Q-SUB is the subwoofer for the Q-Series and can be used to supplement Q1, Q7 and Q10 cabinets in various combinations, either flown or ground stacked. The Q-SUB cabinet is an actively driven bass-reflex design housing a long excursion 18" driver. An M20 threaded flange in the top panel accepts the d&b Loudspeaker stand for the deployment of full range cabinets. Sockets in the front grill and side panels accept Locking pins 8 mm that connect to the Q Splay and Q Front links. The front sockets are specially positioned to also allow the Q Front links to be reversed enabling the lowest Q1 loudspeaker to be secured with a downward angle when ground stacked on top of Q-SUBs. Two runners extend from the rear to the front panel of the cabinet protecting the bottom panel against scratching. Two correspondingly shaped recesses are incorporated in the top panel of each cabinet that accept these runners to prevent cabinet movement when stacking Q-SUBs.

The Q-SUB cabinet is constructed from marine plywood and has an impact resistant paint finish. The front of the loudspeaker cabinet is protected by a rigid metal grill, covered with a replaceable acoustically transparent foam. The cabinet incorporates a pair of handles, and mounted on the rear panel are two EP5 or NL4 connectors wired in parallel and four heavy duty wheels.

System data

Frequency response (-5 dB standard).....40 Hz - 130 Hz
 Frequency response (-5 dB 100 Hz mode).....40 Hz - 100 Hz
 Max. sound pressure (1 m, free field)¹.....
 with D6.....129 dB
 with D12.....133 dB

Loudspeaker data

Nominal impedance.....8 ohms
 Power handling capacity (RMS/peak 10 ms).....400/1600 W
 Components.....18" driver
 Connections.....2 x EP5, optional 2 x NL4
 Pin assignments.....EP5: 3/4, SenseDrive pin 5 (NL4: 2 +/2 -)
 Weight.....42 kg (92.6 lb)

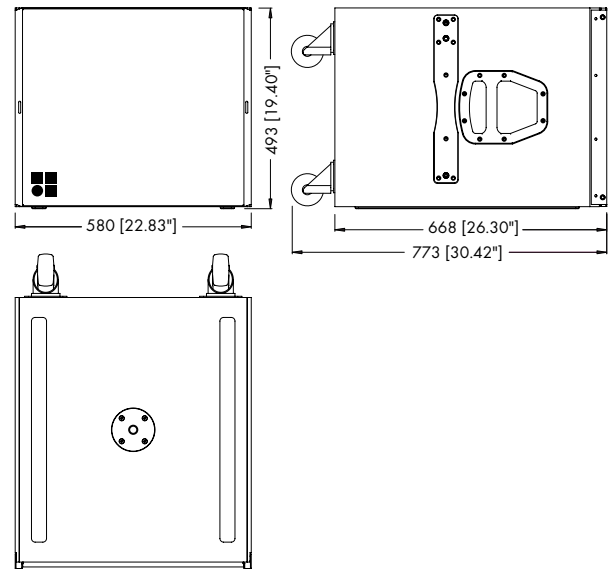

Q-SUB cabinet dimensions in mm [inch]

¹ Broadband measurement, pink noise, crest factor 4, peak measurement, linear weighting

The D6 and D12 configurations

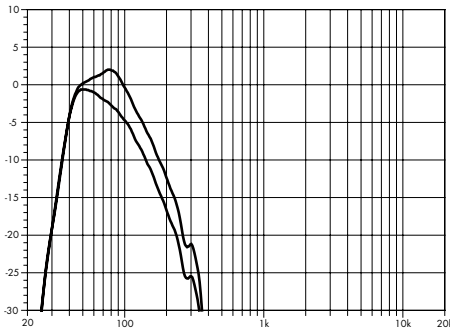

Q-SUB frequency response, standard and 100 Hz modes

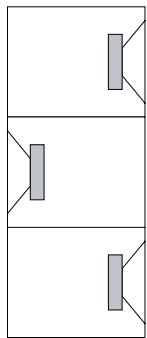

CSA configuration example

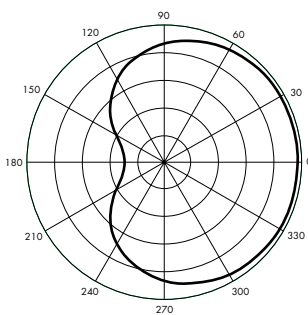

Cardioid polar pattern

Q-SUB with D6 and D12

Selecting Q-SUB mode in the D6 and D12 dual channel amplifiers enables up to two Q-SUB loudspeakers to be driven by the respective channel. In applications with low continuous levels and low ambient temperatures up to three loudspeakers per D12 channel may be connected.

For acoustic adjustment the functions 100 Hz and CSA can be selected.

If the 100 Hz mode is selected, the upper operating frequency of the system is reduced from 130 Hz to 100 Hz.

CSA (Cardioid Subwoofer Array) circuit enables the combination of three or multiples of three subwoofer cabinets into an array that produces exceptional low frequency directivity control. The centre cabinet in a column is physically pointed to the rear, as shown in the drawing opposite and the CSA mode selected on the D6 or D12 channel that powers this cabinet. The forward facing cabinets are driven with a D6 or D12 channel set in the standard mode. The resulting cardioid behaviour of the array will significantly reduce the energy radiated to the rear. For further information please refer to the d&b TI 330 Cardioid Subwoofer Array, which is available for download at www.dbaudio.com. The D12 incorporates d&b SenseDrive for accurate control of driver membranes in d&b subwoofers, resulting in an extremely precise bass performance, even at high levels. SenseDrive is only available using the D12 fitted with EP5 connectors and appropriate 5-wire cabling. For further information please refer to the d&b TI 340 SenseDrive, which is available for download at www.dbaudio.com.

The Q-Series configuration examples

A small sized Q-Series configuration could consist, as shown on the opposite page with the small line array configuration example, of two D12 amplifiers, three Q1 loudspeakers, one Q7 loudspeaker and four Q-SUBs. Three Q1s are driven by one D12 channel and one Q7 from the other, this total load is acceptable for one D12. The Q7 is suspended horizontally with a rotated horn as a downfill and enlarges the vertical coverage in the near field. Four Q-SUBs are driven by the second D12 amplifier configured for Q-SUBs.

A medium sized Q-Series configuration could consist of three D12 amplifiers, six Q1 loudspeakers and six Q-SUBs in CSA mode. Two Q1 loudspeakers are driven from one channel using three in total of the D12 channels configured for Q1s. The forward facing Q-SUBs are driven from two D12 channels set in the standard Q-SUB configuration. The rear facing Q-SUBs are powered by the remaining D12 channel configured for Q-SUBs with the CSA mode selected. In small or medium sized configurations using music program material a one to one ratio of Q1 to Q-SUBs is recommended.

A large sized Q-Series configuration could consist of ten D12 amplifiers, sixteen Q1 loudspeakers, two Q7 loudspeakers, twelve Q-SUBs in CSA configurations and three J-SUBs. All the Q1 loudspeakers are driven by eight D12 channels configured for Q1s. Two Q7 loudspeakers driven by one D6 amplifier are used to cover the near field. Eight forward facing Q-SUBs are driven by four D12 channels set in the standard Q-SUB configuration, whilst the rear facing Q-SUBs are driven by two D12 channels configured for Q-SUBs with the CSA mode selected. The frequency response below 40 Hz can be significantly enriched by the use of J-SUBs with INFRA mode selected which are driven by the remaining three D12 channels. As the horizontal constant directivity of a Q1 column is maintained down to 400 Hz, two columns of Q1s can be arrayed side by side to provide wider horizontal coverage. A horizontal angle of 50° between two columns provides the best compromise between level and frequency response. The two Q7s are used to cover the near field providing sufficient coverage and level.

For further information please refer to the d&b "TI 385 J, Q and T-Series system design, d&b ArrayCalc", which is available for download at www.dbaudio.com.

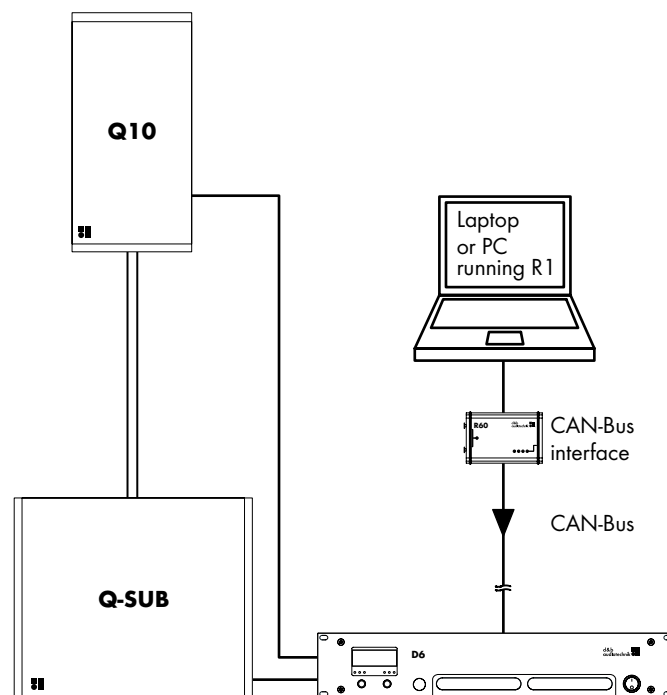

Small basic configuration example

The Q-Series configuration examples

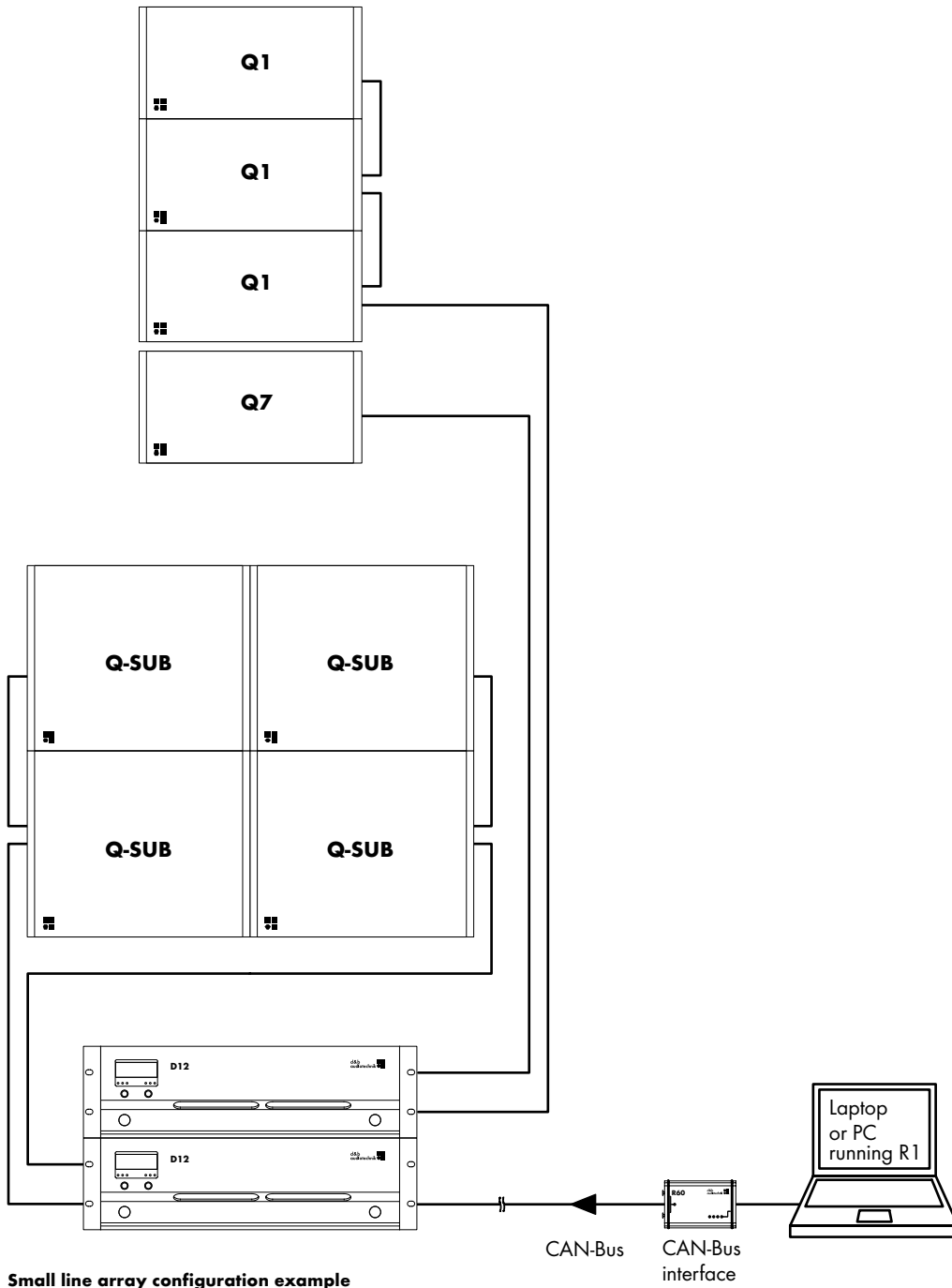

The Q-Series configuration examples

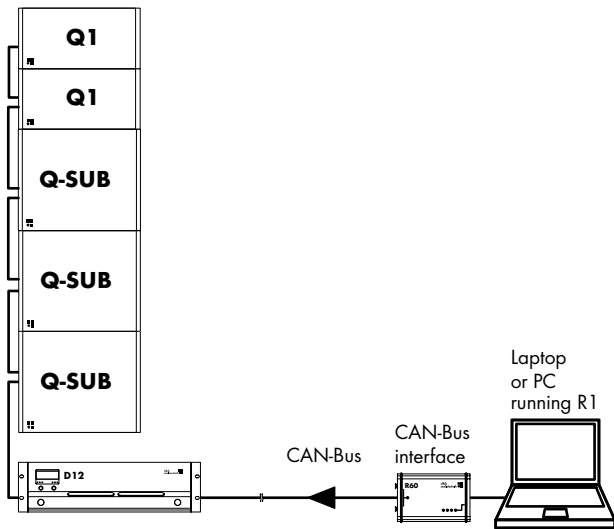

Small ground stacked configuration example

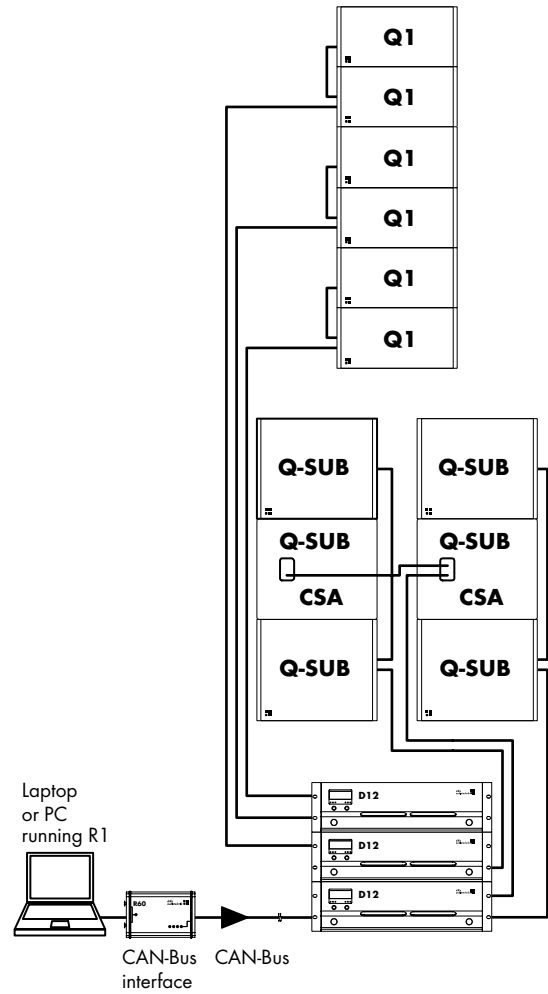

Medium flow and ground stacked example

The d&b ArrayCalc calculator

d&b ArrayCalc calculator

For both acoustical and safety reasons d&b line arrays must be designed using the d&b ArrayCalc simulation tool. From Version 5 onwards it is a program available for operation with both Microsoft Windows¹, Version XP or higher, and Mac OS² X, Version 10.4.10 or higher. The features include defining the quantity and aiming of loudspeakers, calculating SPL mappings, subwoofer array setups, time alignment between arrays, weights and overall dimensions of arrays as well as calculating printable rigging plots and parts lists.

ArrayCalc calculates and displays the physical parameters of up to seven stereo pairs or individual arrays including the mechanical load conditions within a column, load safety information, load values for rigging points and displays load safety warnings should an overload occur. ArrayCalc uses a sophisticated mathematical model synthesizing each loudspeaker's wave front with an array of closely spaced point sources. Using complex data (phase information) level distribution is calculated in multiple frequency bands for up to five main audience areas and side tiers. It also calculates the resulting dispersion of horizontally arrayed subwoofers at different frequencies and calculates the delay values to achieve a desired far field dispersion. The display of the arrival times of the individual arrays at a selectable test point allows a precise time alignment. The ArrayCalc software comprises six main sheets; Arrays and SUB Array, 3D Plot, Alignment, Measuring, Rigging and Parts list.

The Array Page allows up to five different listening planes to be defined, with optional side extensions. The left section allows editing of the project, the room, various array types and quantities, various individual and grouped controls and monitoring functions and the definition of the profile of each array. For every single loudspeaker, Line/Arc and HFC modes can be configured and headroom is monitored using a virtual GR LED. An Auto splay function proposes initial vertical splay angles between the loudspeakers; these can then be adjusted manually. The middle section displays a side view of the selected array, displaying overall mechanical size and rigging information. In the right section the top view graphic shows a plan view of the audience areas, the locations of the arrays and their horizontal aiming while highlighting the selected one. The profile shows a cross section through the active listening plane on the horizontal aiming axis of the selected array and the aiming axis of each loudspeaker. The Direct sound level vs. distance plot shows the direct sound level over distance for either: two selectable frequency bands, or differently weighted

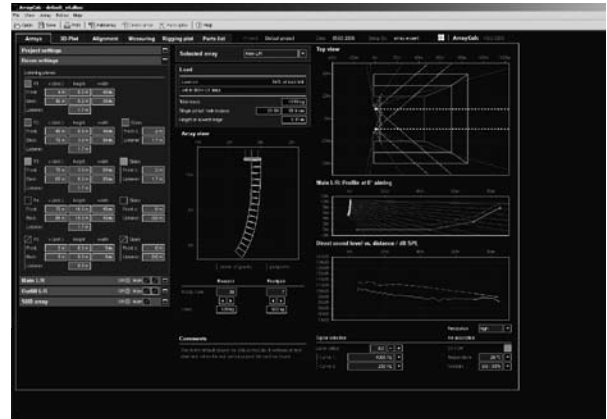

Room Settings

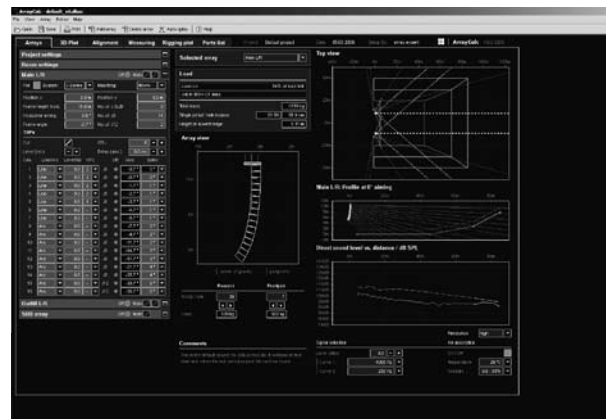

Arrays

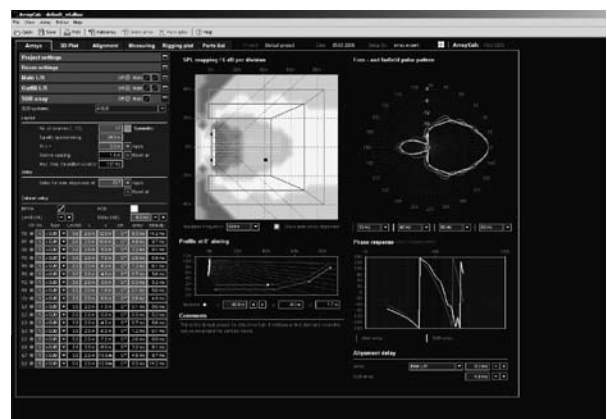

SUB Array

The d&b ArrayCalc calculator

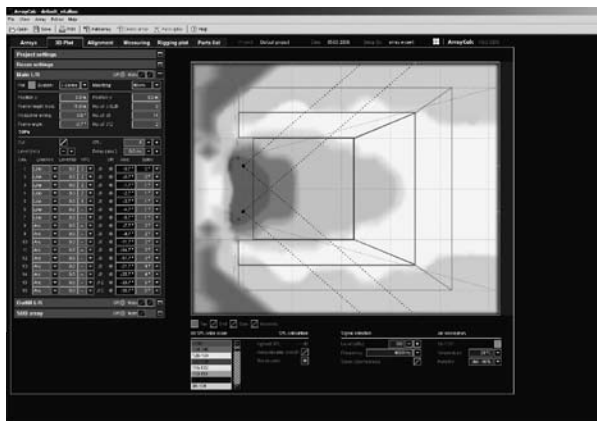

3D Plot

broadband summed levels for different input signals and levels. Also air absorption depending on temperature and relative humidity can be taken into account.

The SUB Array section allows the definition and placement of up to twenty five subwoofer positions. Based on subwoofer type and positioning, the resulting coverage and far field polar patterns are calculated for multiple frequencies. The software will also generate the necessary delay times needed to achieve a specific nominal dispersion angle. Calculated phase response plots allow simulation of time alignment between flown arrays and the subwoofer array for a given reference point.

On the 3D Plot page, the summed SPL of all active arrays can be mapped onto the listening planes optionally using complex summation for low frequencies.

The Alignment page displays the arrival times of multiple arrays for a selectable reference point to help with optimisation. The Measuring sheet can be used to define the coordinates of the listening planes using trigonometry and data from a laser inclinometer and a rangefinder.

The Rigging plot is a printable sheet that displays the physical parameters and load information such as array dimensions, weights and rigging point locations. The Parts list is a printable sheet providing a detailed list of all the loudspeakers and rigging components required for the design.

Both the d&b "TI 385 J, Q and T-Series system design, d&b ArrayCalc" which provides further information and the ArrayCalc program itself, are available for download at www.dbaudio.com.

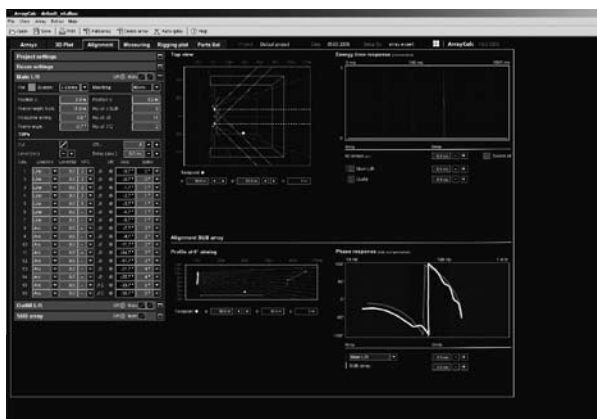

Alignment

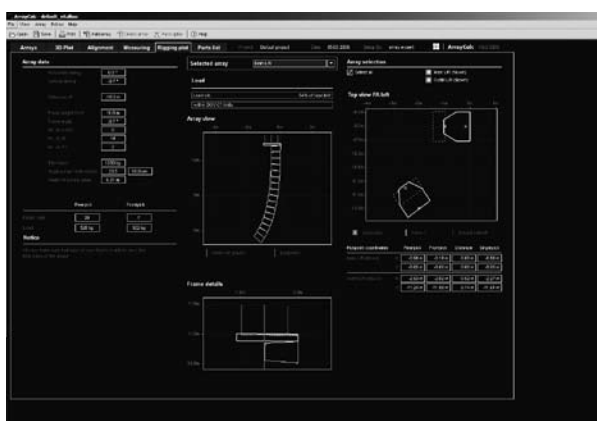

Rigging Plot

¹ Microsoft Windows is a registered trademark or trademark of Microsoft Corporation in the United States and/or other countries

² Mac OS is a trademark of Apple Inc., registered in the U.S. and other countries

The Q-Series product overview

	Code	Description
Loudspeakers	Z0501.000	Q1 Loudspeaker EP5 connector (including Z5154 Q Rigging set)
	Z0501.001	Q1 Loudspeaker NL4 connector (including Z5154 Q Rigging set)
	Z0507.000	Q7 Loudspeaker EP5 connector
	Z0507.001	Q7 Loudspeaker NL4 connector
	Z0508.000	Q10 Loudspeaker EP5 connector
	Z0508.001	Q10 Loudspeaker NL4 connector
	Z0510.000	Q Subwoofer EP5 connector
	Z0510.001	Q Subwoofer NL4 connector
Amplifiers	Z2700.000	D6 Amplifier NL4 (85 - 285 V)
	Z2600.000	D12 Amplifier EP5 (115/230 V)
	Z2600.001	D12 Amplifier NL4 (115/230 V)
	Z2600.300	D12 Amplifier EP5 (100/200 V)
	Z2600.301	D12 Amplifier NL4 (100/200 V)
Remote network	Z3000.000	R1 Remote control software (available as a download from www.dbaudio.com)
	Z3001.000	R10 Service software (available as a download from www.dbaudio.com)
	Z6118.000	R60 USB to CAN interface
	Z6124.000	R70 Ethernet to CAN interface
	Z6116.000	RJ 45 M Terminator
	Z6122.000	Bopla mounting clamp
	Z6123.000	Bopla mounting clamp upright
Cables	Z2294.xxx	MC5 EP5 cable various length
	Z2291.xxx	MC4 NL4 cable various length
	Z2296.000	NL4 Extension adapter
	K3110.000	MC5 cable unterminated
	K3106.002	MC4 cable unterminated
Racks	E7419.000	Touring rack 3 RU, 19" DD, shock mounted, handles, window
	E7420.000	Touring rack 6 RU, 19" DD, shock mounted, handles, window, wheels
	E7424.000	Touring rack 9 RU, 19" DD, shock mounted, handles, window, wheels
	E7211.000	Touring rack 2 RU, 19" DD, shock mounted, handles

The Q-Series product overview

	Code	Description
Cases	E7430.000	Touring case 2 x Q1 / Q7 / Q10 wheels
	E7431.000	Touring case 3 x Q1 / Q7 / Q10 wheels
	E7432.000	Touring case 2 x Q1 / Q7 / Q10 wheels, Z5150 Q Swivel bracket, tray
	E7433.000	Touring case 2 x Q Flying frame wheels, flexible cable store, 2 trays
Lids	E7921.000	Q Subwoofer wooden lid
Accessories	Z5159.000	Q Flying frame
	Z5151.000	Q Splay link
	Z5152.000	Q Front link
	Z5153.000	Locking pins 8 mm (linked in pairs with steel wire)
	Z5154.000	Q Rigging set (supplied with Q1 includes 2 x Z5151, Z5152 and 4 x Z5153)
	Z5160.000	Q Load adapter
	Z5155.000	Q Hoist connector chain (supplied with 2 x E6507 1t Shackles)
	Z5161.000	Q Flying bracket
	Z5150.000	Q Swivel bracket
	Z5175.000	Qi Horizontal bracket
	Z5044.000	MAX Bracket connector
	Z5156.000	Q Flying adapter
	Z5020.000	Flying adapter 02
	Z5025.000	Flying adapter 03
	Z5010.000	TV spigot with fixing plate
	Z5015.000	TV spigot for flying adapter 02
	Z5048.000	Flying pin 10 mm
	Z5012.500	Pipe clamp for TV spigot
	Z5147.001	Rota clamp
	Z5009.000	Loudspeaker stand with winder
	Z5013.000	Loudspeaker stand winder M20
	Z5024.000	Loudspeaker stand adapter
	E6507.000	1t Shackle
Q9032.000	M10 Safety eyebolt	
Misc.	Z5060.000	Anti-slip coating 1 kg / 2.2 lb
	Z5061.000	Standard cabinet paint 1 kg / 2.2 lb

