

ML 3000

The most compact VCA mixer available today, but don't let its small size and modest price fool you – this console is packed with all the tools you need for professional live sound mixing. The **ML3000** earns its place in any PA system - the perfect investment!

ML3000 is a dual function, LCRplus, 4 group, 8 aux, 8x4 matrix, VCA console. Frame sizes range from 24+2 to 48+2 channels, with B option for more stereo channels.



FEATURES

- ▶ 24+2, 32+2, 40+2, 48+2 channel frames
- ▶ 2 extra dual input stereo channels fitted as standard
- ▶ B option for 4 extra dual stereo in place of mono channels
- ▶ 8 VCA groups for level control
- ▶ Dual functionality for mixing front-of-house, stage monitors or both
- ▶ Monitor mode provides auxes with faders, inserts, mutes and meters
- ▶ LCRplus panning available from channels and groups
- ▶ 4 audio groups for inserting processors or feeding the matrix
- ▶ 8 aux sends plus aux 7-8 stereo mode for creating a true stereo mix
- ▶ 8x4 matrix with inserts and external inputs
- ▶ 8 mute groups
- ▶ 4 band EQ with swept mid range
- ▶ Swept 20-400Hz HPF
- ▶ Stereos can mix two balanced stereo sources into one channel
- ▶ 128 snapshot memories for MIDI/RS232 recall of VCA assignments and mutes
- ▶ **ALLEN&HEATH ML Archiver** software available for PC control of the memories
- ▶ Talkback to any of the fader masters and LCR outputs
- ▶ PFL override AFL for quick input/output monitoring
- ▶ Fader driven engineers listen wedge feed with insert in monitor mode
- ▶ Simultaneous LED bar and moving coil VU metering of all main outputs and P/AFL
- ▶ Channel meters
- ▶ Separate stereo headphones and local monitor control
- ▶ LCR to stereo engineers monitor capability
- ▶ 1kHz oscillator / pink noise generator
- ▶ Preamp input capability for mic or line up to +30dBu
- ▶ Main, group, aux and matrix outputs on balanced XLR
- ▶ 4-pin XLR lamp sockets – **ALLEN&HEATH** LEDlamp available
- ▶ Uses RPS11 high performance external linear power supply
- ▶ Optional RPSD2 dual supply combiner to link another RPS11 for backup
- ▶ Optional Sys-Link V2 input/output option to link consoles for more channels
- ▶ Internal aux jumper options for pre-insert, pre/post-EQ, pre/post-mute settings
- ▶ Internal direct output jumper options for pre/post-fade or to use aux 1 level trim



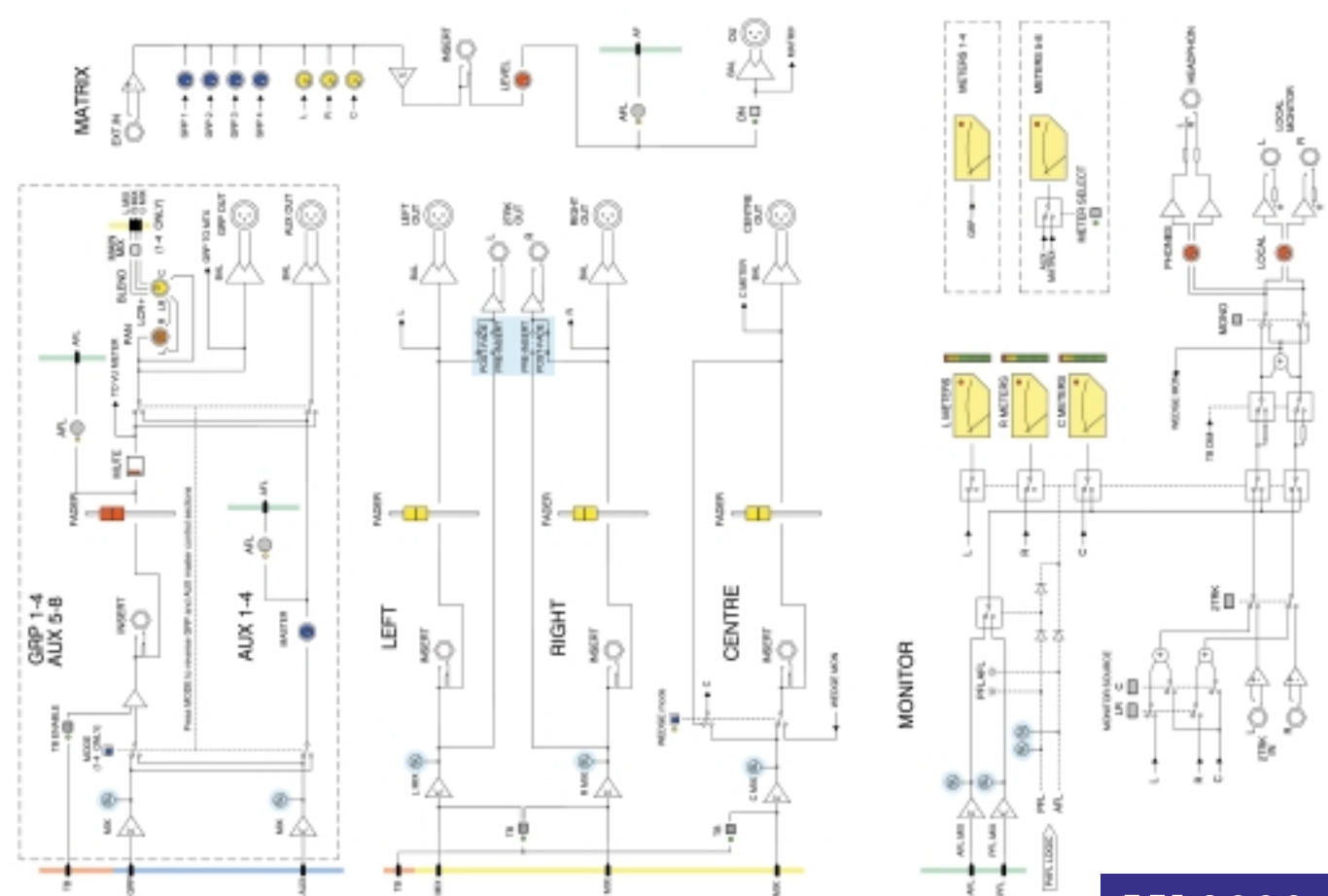

ML3000
System Block Diagram

