

Approximate Projection Distances

Type	On-Axis Wide Fixed Lens	On-Axis Wide Fixed Lens	Wide Zoom Lens	On-Axis Wide Fixed Lens	Wide Zoom Lens	Wide Zoom Lens	Wide Zoom Lens	Standard Zoom Lens	Standard Zoom Lens	Semi-Long Zoom Lens	Long Zoom Lens	Ultra-Long Zoom Lens	
Part Number	LNS-W07	LNS-W03	LNS-W05	LNS-W01Z	LNS-W06	LNS-W02Z	LNS-W04	LNS-S02Z	LNS-S03	LNS-M01Z	LNS-T02	LNS-T03	
Image													
Zoom/Focus	Fixed/Manual	Fixed/Manual	x1.4/ Motor-Driven	Fixed/Manual	x1.3/ Motor-Driven	x1.2/ Motor-Driven	x1.3/ Motor-Driven	x1.3/ Motor-Driven	x1.3/ Motor-Driven	x1.2/ Motor-Driven	x1.4/ Motor-Driven	x1.4/ Motor-Driven	
Twin Stack Support*1	No	No	Yes	No	Yes	Yes	Yes	Yes	Yes	Yes	Yes	Yes	
Image Size	40"-600"	40"-600"	40"-600"	40"-600"	40"-600"	40"-600"	40"-600"	40"-600"	100"-600"	40"-600"	40"-600"	40"-600"	
PLC-XF71	Optical Axis	H1:H2 W1:W2	1:1 (Fixed)	8.1 - 1.8 (approx.)	8.1 - 1.8 (approx.)	8.1 - 1.8 (approx.)	8.1 - 1.8 (approx.)	10.0 - 0.1 (approx.)	8.1 - 1.8 (approx.)	8.1 - 1.8 (approx.)	8.1 - 1.8 (approx.)	8.1 - 1.8 (approx.)	
	Throw Distance*2 (unit: m (feet))	40"	0.60 (2.0)	0.91 (3.0)	0.9 - 1.2 (3.0 - 3.8)	1.1 - 1.4 (3.5 - 4.7)	1.1 - 1.6 (3.5 - 5.1)	1.5 - 2.0 (4.8 - 6.5)	2.3 - 3.2 (approx.)	2.3 - 3.2 (approx.)	2.9 - 3.7 (9.4 - 12.1)	3.7 - 5.1 (12.3 - 16.8)	5.3 - 7.6 (17.3 - 24.8)
		60"	0.93 (3.1)	1.41 (4.6)	1.4 - 1.8 (4.6 - 5.9)	1.6 - 2.2 (5.4 - 7.1)	1.8 - 2.4 (5.9 - 7.9)	2.3 - 3.1 (7.6 - 10.1)	3.3 - 4.2 (10.4 - 13.7)	3.3 - 4.2 (10.4 - 13.7)	4.3 - 5.5 (14.0 - 18.0)	5.5 - 7.6 (18.1 - 24.9)	7.7 - 11.2 (25.4 - 36.7)
		80"	1.27 (4.2)	1.90 (6.2)	1.9 - 2.4 (6.2 - 8.0)	2.2 - 2.9 (7.3 - 9.6)	2.4 - 3.2 (8.0 - 10.8)	3.2 - 4.2 (10.4 - 13.7)	4.0 - 5.3 (13.1 - 17.3)	4.0 - 5.3 (13.1 - 17.3)	5.6 - 7.3 (18.5 - 23.9)	7.3 - 10.0 (23.9 - 33.0)	10.2 - 14.6 (33.4 - 48.6)
		100"	1.60 (5.3)	2.40 (7.9)	2.4 - 3.1 (7.8 - 10.1)	2.8 - 3.7 (9.2 - 12.1)	3.1 - 4.1 (10.1 - 13.4)	4.0 - 5.3 (13.1 - 17.3)	5.2 - 7.1 (17.1 - 23.9)	5.2 - 7.1 (17.1 - 23.9)	7.0 - 9.1 (23.1 - 29.8)	9.0 - 12.5 (29.6 - 41.1)	12.6 - 18.4 (41.5 - 60.4)
		150"	2.43 (8.0)	3.64 (12.0)	3.6 - 4.7 (11.8 - 15.3)	4.3 - 5.6 (14.0 - 18.0)	4.7 - 6.2 (15.4 - 20.3)	6.1 - 8.0 (20.0 - 26.2)	7.9 - 10.7 (26.0 - 35.2)	7.9 - 10.7 (26.0 - 35.2)	10.5 - 13.6 (34.5 - 44.5)	13.4 - 18.7 (44.0 - 61.3)	18.8 - 27.4 (61.7 - 90.1)
		200"	3.27 (10.7)	4.88 (16.0)	4.8 - 6.2 (15.8 - 20.5)	5.7 - 7.5 (18.7 - 24.9)	6.3 - 8.3 (20.6 - 27.2)	8.2 - 10.7 (26.9 - 35.2)	10.6 - 14.4 (34.8 - 47.1)	10.6 - 14.4 (34.8 - 47.1)	14.0 - 18.1 (45.9 - 59.2)	17.8 - 24.9 (58.5 - 81.5)	24.8 - 36.5 (81.8 - 119.7)
		250"	4.10 (13.5)	6.12 (20.1)	6.0 - 7.8 (19.8 - 26.1)	7.2 - 9.3 (23.5 - 30.7)	7.9 - 10.4 (25.9 - 34.0)	10.3 - 13.5 (33.8 - 44.2)	13.3 - 18.0 (43.8 - 59.0)	13.3 - 18.0 (43.8 - 59.0)	17.4 - 22.5 (57.2 - 74.0)	22.2 - 31.0 (72.9 - 101.8)	31.1 - 45.5 (102.0 - 149.3)
		300"	4.93 (16.2)	7.37 (24.2)	7.3 - 9.4 (23.8 - 30.9)	8.6 - 11.2 (28.2 - 36.8)	9.5 - 12.5 (31.2 - 40.9)	12.4 - 16.2 (40.7 - 53.2)	16.0 - 21.6 (52.5 - 70.9)	16.0 - 21.6 (52.5 - 70.9)	20.9 - 27.0 (66.6 - 88.7)	26.6 - 37.2 (87.3 - 122.0)	37.2 - 54.6 (122.2 - 179.0)
		PLV-WF20	Image Size	30"-400"	30"-400"	30"-400"	30"-400"	30"-400"	30"-400"	70"-400"	30"-400"	30"-400"	30"-400"
PLV-WF20	Optical Axis	H1:H2 W1:W2	3.1-1.3 (approx.)	4.1-1.4 (approx.)	10.0-0.1 (approx.)	10.3-3.1 (approx.)	10.3-3.1 (approx.)	10.3-3.1 (approx.)	10.3-3.1 (approx.)	10.3-3.1 (approx.)	10.3-3.1 (approx.)	10.3-3.1 (approx.)	
	Throw Distance*2 (unit: m (feet))	40"	0.63 (2.1)	0.92 (3.0)	1.1 - 1.5 (3.5 - 5.1)	1.39 (4.6)	1.4 - 1.8 (4.6 - 5.9)	1.6 - 2.2 (5.4 - 7.1)	1.8 - 2.4 (5.8 - 7.9)	2.3 - 3.1 (7.5 - 10.0)	4.2 - 5.4 (13.8 - 17.8)	5.5 - 7.5 (17.9 - 24.7)	7.7 - 11.1 (25.2 - 36.4)
		60"	0.97 (3.2)	1.42 (4.7)	1.7 - 2.4 (5.4 - 7.7)	2.13 (7.0)	2.1 - 2.7 (6.9 - 9.0)	2.5 - 3.8 (8.2 - 10.8)	2.7 - 3.6 (9.0 - 11.9)	3.5 - 4.7 (11.7 - 15.4)	6.3 - 8.1 (20.8 - 26.6)	8.1 - 11.2 (26.5 - 36.7)	11.3 - 16.5 (37.2 - 54.1)
		80"	1.31 (4.3)	1.92 (6.3)	2.2 - 3.2 (7.4 - 10.4)	2.87 (9.4)	2.8 - 3.7 (9.3 - 12.1)	3.4 - 4.4 (11.0 - 14.4)	3.7 - 4.9 (12.1 - 16.0)	4.8 - 6.3 (15.8 - 20.7)	6.2 - 8.5 (20.5 - 27.8)	8.3 - 10.8 (27.4 - 35.4)	10.7 - 14.9 (35.1 - 48.7)
		100"	1.66 (5.4)	2.41 (7.9)	2.8 - 4.0 (9.3 - 13.1)	3.61 (11.8)	3.6 - 4.6 (11.7 - 15.1)	4.2 - 5.5 (13.8 - 18.1)	4.6 - 6.1 (15.2 - 20.1)	6.1 - 7.9 (19.9 - 26.0)	7.8 - 10.6 (25.7 - 34.9)	10.4 - 13.5 (34.2 - 44.1)	13.3 - 18.5 (43.7 - 60.8)
		150"	2.52 (8.3)	3.65 (12.0)	4.3 - 6.0 (14.1 - 19.8)	5.46 (17.9)	5.4 - 7.0 (17.6 - 22.9)	6.4 - 8.3 (20.9 - 27.3)	7.0 - 9.2 (23.1 - 30.3)	9.2 - 12.0 (30.1 - 39.4)	11.8 - 16.0 (38.9 - 53.6)	15.6 - 20.1 (51.1 - 66.1)	19.8 - 27.7 (65.1 - 90.9)
		200"	3.38 (11.1)	4.89 (16.0)	5.7 - 8.1 (18.8 - 26.4)	7.30 (24.0)	7.2 - 9.3 (23.6 - 30.6)	8.5 - 11.1 (28.0 - 36.5)	9.4 - 12.4 (30.9 - 40.6)	12.3 - 16.1 (40.4 - 52.7)	15.9 - 21.4 (52.0 - 70.3)	20.7 - 28.8 (66.0 - 98.0)	26.4 - 36.9 (86.6 - 121.0)
		250"	4.23 (13.9)	6.13 (20.1)	7.2 - 10.1 (23.6 - 33.1)	9.15 (30.0)	9.0 - 11.7 (29.5 - 38.4)	10.7 - 13.9 (35.1 - 46.7)	11.8 - 15.5 (38.7 - 50.8)	15.5 - 20.1 (50.7 - 66.1)	19.9 - 26.9 (65.2 - 98.0)	22.9 - 32.5 (74.0 - 101.1)	30.1 - 47.6 (95.2 - 141.7)
		300"	5.09 (16.7)	7.37 (24.2)	8.7 - 12.1 (28.4 - 38.8)	10.99 (36.1)	10.8 - 14.0 (35.5 - 46.1)	12.8 - 16.7 (42.1 - 54.9)	14.2 - 18.6 (46.8 - 61.0)	18.6 - 24.2 (61.0 - 79.5)	23.9 - 32.2 (78.3 - 105.7)	31.1 - 40.2 (101.9 - 131.8)	38.5 - 55.2 (123.5 - 191.2)

*1: Full lens performance may not be available at some projection distances.
*2: Approximate projection distances are calculated based on lens specifications. Individual lenses may diverge from this figure by up to 5% due to slight variations in lens size and shape.

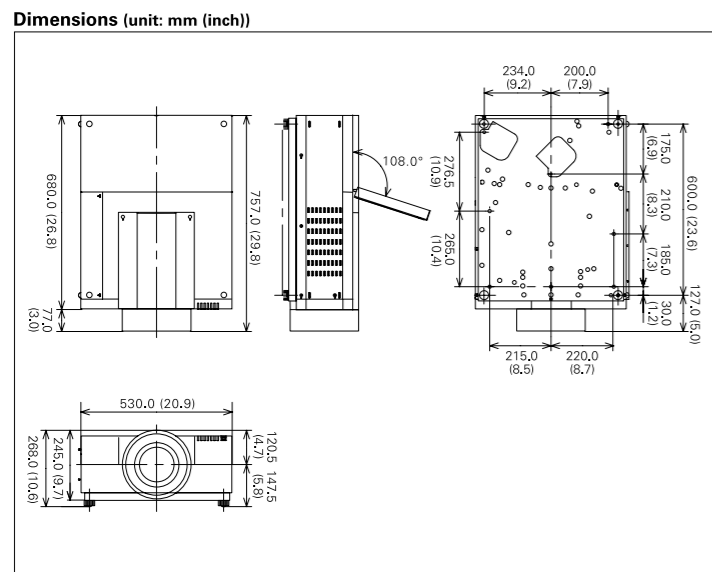

Specifications	PLC-XF71	PLV-WF20
Model	PLC-XF71	PLV-WF20
Type	3-color LCD shutter projection	
Optics	Dichroic mirror separation/prism synthesis	
LCD Size	1.8	1.2
panels Number of pixels	1024 x 768 x 3	1366 x 800 x 3
Projection lens	Lenses sold separately.	
Lamp (output/type)	330 W NSHA x 2	
Projection size	Lenses sold separately.	
Color reproduction	Approx. 1.07 billion	
Effective luminous flux (brightness, lm)	10000 (With separately available lens LNS-S03.)	6000 (With separately available lens LNS-S03.)
Uniformity	90 % (corner to center)	
Supported scanning frequencies	H/V sync 15 - 120Hz, 48 - 120Hz Dot clock 230 MHz or less	
Supported RGB resolutions	WUXGA/ UXGA/ SXGA+/ SXGA/ WXGA/ XGA/ SVGA/ VGA/ MAC	
Signal input terminal	inputs1: DVI-D (HDCP) / RGB (D-Sub 15 pin) inputs2: RGBHV / Y / VIDEO, Pb / Cb, Pr / Cr (BNC x 5) S-Video (Mini-DIN4) inputs3: For option board inputs4: For option board	
Other I/O	RS232C IN/ OUT (D-sub 9pin x 2), Wired remote control (mini-jack)	
Operating temperature	5 - 40 °C	
Power supply	100 - 120 V / 200 - 240 V AC	
Power consumption	950 W	
Dimensions (W x H x D)	530.0 x 268.0 x 757.0 mm (20.9 x 10.6 x 29.8 inch)	
Weight	27.6 kg (60.9 lbs)	
Accessories	<ul style="list-style-type: none"> Wireless Remote Unite (Two "AA" type Batteries) Owners Manual (CD-Rom & Quick Reference Guide) Computer Cable (D-sub15 - D-sub15) AC Cord x 1 (depending on destination) Lens Attachment x 2 - Lens spacer - Light block sheet x 3 PIN code Level - Real Color Manager Pro CD-Rom x 1 	

Replacement Lamp type No: PLC-XF71: POA-LMP128(610 341 9497), PLV-WF20: POA-LMP104(610 337 0262)
*Specifications as of November 20, 2008 subject to change.
*All product names and company names are trademarks or registered trademarks of their respective companies

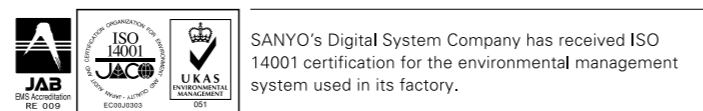
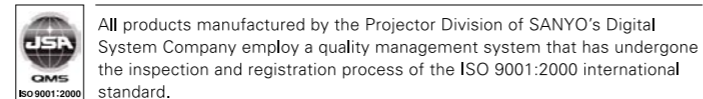

<http://www.sanyo-lcdp.com/>

Caution: Please consult the instruction manual to ensure safe and proper operation of the product.

Distributed by:



SANYO Electric Co., Ltd.
Digital System company

© 2008 SANYO Printed in Japan 2008.11 St.
SML130

Think GAIA
For Life and the Earth



Multimedia Projector

PLC-XF71
PLV-WF20



Powerful Images for Large Venues and Digital Signage
The Industry's Brightest*1 2-Lamp Projectors
PLC-XF71/ PLV-WF20

*1 The PLC-XF71 only. For 2-lamp projectors as of November 20, 2008



Large-Screen Solutions for Your Business.

Ideal for Large Conference and Other Halls, Digital Signage Applications, Seminars and Lecture Halls



digital signage

Industry's Highest*2 10,000-Lumens Brightness with Dual-Lamp System

PLC-XF71

Two high-output 330 W lamps and a new optical engine have achieved the industry's highest*2 brightness of 10,000 lumens.

PLV-WF20: 6000 lumens
*2: For a dual-lamp projector, as of November 20, 2008. In dual-lamp mode and with the optional LNS-S03 lens.

17:10 Wide-Screen Aspect Ratio LCD Panels

PLV-WF20

Each of the three LCD panels in the PLV-WF20 has 1,366 x 800 dots, giving a total of 3.27 million pixels to ensure high-resolution real WXGA(1,366 x 768, 1,280 x 800) and real XGA image quality.

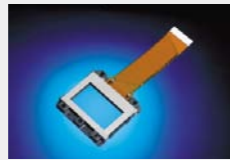

Dual-Lamp Light-Combining Technology

The new light-combining system was developed after extensively reexamining the conventional dual-lamp layout. The new system uses three mirrors to achieve uniform light output from two lamps, reducing color irregularities and delivering high image quality.

Newly developed system (mirror system)

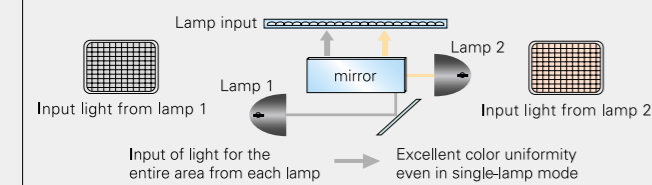

Active Maintenance Filter (AMF)

The AMF sensor detects the intake air volume. If the volume is less than the prescribed level, the filter is automatically round and a clean filter surface is set in position. The filter can also be replaced without having to use any tools.



High Performance Optical Engine

We enhanced brightness by combining advanced optical components under optimal conditions. We also maximized cooling technology to increase light efficiency factors such as luminance and lamp output. Together, they achieve a high brightness level and low power consumption.

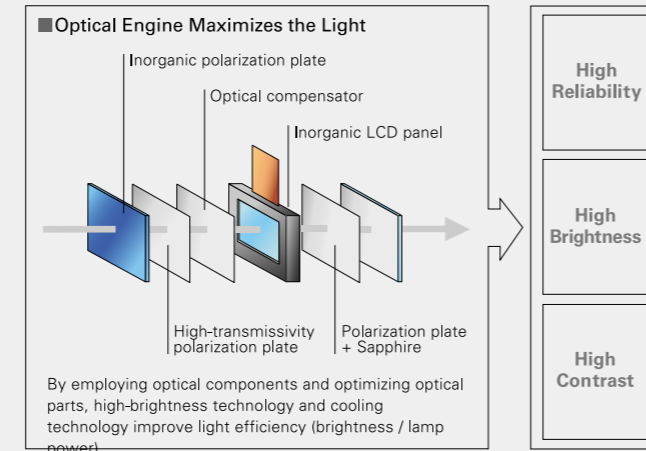

Power Lens Shift

The motor-driven lens shift function*3 makes it easy to adjust the projected image position without having to move the projector itself. This greatly simplifies projector set-up. It also helps when adjust the images from two stacked units.

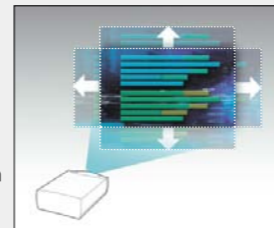

*3: Depends on the mounted lens.

Optional Lenses

From short to long focus types, Sanyo offers a variety of optional lenses to match the projection distance, screen size, and projection conditions.

High-Contrast Design

This advanced optical system achieves high contrast*4 to project high-quality images with rich black reproduction, maximizing the quality of the video signals.

*4: Contrast ratio (full on/ full off) of 3,000:1 (PLC-XF71), 2000:1 (PLV-WF20)

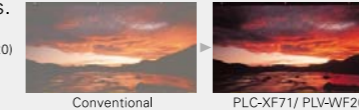

Lens Center Layout (Symmetry Design)

A Symmetry Design is used (left-right center layout = left-right centered optical axis). This makes on-site setup easier.



Multi-Versatile Interface Platform System

Interfaces such as video boards and RGB boards can be mounted in available slots.*5

*5: Some boards must be mounted in specific slots.

Mechanical shutter

There's also a Mechanical Shutter System which is popular for a variety of elite professional uses. The amazing PLC-XF71/ PLV-WF20 fills the needs of a host of demanding business venues including meeting, entertainment and promotional applications.



Other Features and Functions

- 360-degree tilt angle
- Network Functions (Optional)
- 3D Digital Noise Reduction
- Power management function
- Easy lamp replacement
- Digital keystone function (Vertical: Max ±40 Horizontal: Max ±20)

lecture room



PLC-X F 71 XGA 10000 lm
PLV-WF20 WXGA 6000 lm